

**Wholesale Parcels Services
User Guide
for
Inward Mail Centres**

Document History				
Date	Author	Version No.	Document Title and Rational for Revision	Revision Summary
Jan 2013	Charlotte Marshall	1	RMW_ Parcels User Guide v1	New User Guide –Parcels Services
July 2013	Charlotte Marshall	2	RMW_ Parcels User Guide v2. Inclusion of changes and enhancements to service requirements.	Inclusion of UGA 26 as notified in July. Update of terminology and specification enhancements. Details of requirements for a new Schedule option Acceptance By Vehicle.
Jan 2014	Charlotte Marshall	3	RMW_ Parcels User Guide v3. Inclusion of published UGA. Amendments relevant to Tariff 2014	UGA 27 & 28 relating to H&S and updates as published in Tariff 2014.
Aug 2014	Charlotte Marshall	4	RMW_ Parcels User Guide v4. Inclusion of published UGA System changes	UGA Epro to DocketHUB migration
Mar 15	Stephen O'Hare	5	RMW Parcels User Guide. Inclusion of published UGA. Manifest update as a result of Epro to DocketHUB migration and withdrawal of Change Notice 001	UGA 33 Epro to DocketHUB migration Withdrawal of Change Notice 001

Table of Contents:Wholesale Parcels Services User Guide.....	1
Document History.....	2
Table of Contents:	3
Table of Figures:.....	5
Parcel Services for Inward Mail Centres.....	6
1 Overview of Parcels Services.....	7
2 Key features and requirements.....	8
2.1 Service Standard	8
2.2 Parcels Services Summary.....	8
2.3 System Requirements	8
2.4 Pricing options	8
2.5 Addressing Standards.....	9
2.6 Address and Postcode Accuracy.....	9
3 Indicum.....	10
3.1 Indicum.....	10
3.2 Indicum Size	13
3.3 Stamp-like Indicum.....	13
3.4 Return Addresses and Undeliverable Mail.....	13
4 Enquiries & Complaints	16
5 Preparing Mailing Items	17
5.1 Step 1: Format Segregation.....	17
5.2 Step 2: Sortation split.....	17
5.3 Step 3: Weight Band Segregation.....	18
6 Sortation & Presentation.....	19
6.1 Minimum Container Fills (Bags, ALPS)	19
6.2 Under Volume Containers (Bags, ALPS).....	19
6.3 Presenting your Mailing Items in Bags	20
6.4 Presenting your Mailing Items in ALPS	21
6.5 Unwrapped Bundle Postings.....	22
6.6 Unbagged Bundle Postings	22
6.7 Unwrapped and Unbagged bundle mailing.....	22
6.8 Presenting Mailing Items as Mixed Weight	22
7 Customer Final Labelling Requirements	26
7.1 Label Positioning Guide.....	26
7.2 Customer defined information field	26
7.3 Royal Mail defined information field	26
7.4 Size Guide	28
7.5 Producing Customer Final Labels	28
7.6 The different Labelling methods explained	29
7.7 Contingency plan	29
7.8 Chosen Labelling Method.....	29
7.9 Data formats	29
8 Equipment for Postings.....	31
8.1 Blank Labels and Bag Ties	31
8.2 Bags	31
8.3 Yorks/Auto Level Packet Sleeved (ALPS).....	31
8.4 Property	32
9 Documentation	33
9.1 Posting Dockets	33
9.2 Contingency arrangements	33
9.3 Calculating Charges.....	33
9.4 Manifests.....	33

9.5	Agreeing the Client Report	37
9.6	Early Release Schedule	37
9.7	Waybill documentation	37
9.8	York card documentation.....	38
9.9	Segregation by Format York card documentation	38
9.10	York Manifest	39
10	Calculating the Postage.....	40
10.1	Postage for Mailing Items in weight band 1 (WB1).....	40
10.2	Postage for Mailing Items in weight band 2 (WB2).....	40
11	Despatching the Posting	41
11.1	Pre - Notification of Posting	41
11.2	7 Working Day Rolling Forecast	41
11.3	Pre-notification.....	41
11.4	06:30am Posting Docket and Manifests.....	41
11.5	Forecast for Key National Postings (KNP)	42
12	Access Times	43
12.1	Access Windows.....	43
12.2	Access Slots	43
12.3	Access Slot Change Request Process	43
12.4	Ad-hoc & Additional Access Slot Booking Process	43
12.5	Multiple Vehicles per Access Slot	44
13	Handover	45
13.1	Security Procedures.....	45
13.2	Health and Safety.....	45
13.3	Dock Allocation.....	45
13.4	Unloading & Handover	45
13.5	Amalgamation of discrete Daily Postings in Yorks	46
13.6	Exiting the Site.....	46
13.7	Contingency	46
14	Revenue Protection	47
15	Procedures for Handling Non-compliant Postings	47
15.1	Pre-notification and Pre -Advice	48
15.2	Arrival	49
15.3	Documentation.....	50
15.4	Indicium.....	51
15.5	Addressing Standards.....	52
15.6	Mail Presentation	52
15.7	Health and Safety.....	58
	Appendix A: Addressing Mailing Items	59
	Appendix B: Access Selection Files	62
	Appendix C: Unwrapped Specification	63
	Appendix D: Strapped Bundle/Un-bagged Specification.....	64
	Appendix E: Key National Posting (KNP).....	68
	Appendix F: Zonal Option.....	71
	Appendix G: Definitions and Interpretations.....	74
	Appendix H: Prohibited Items, Restricted Items and Valuables.	78

Table of Figures:¹

Figure 1: Summary of Parcel Services.....	8
Figure 2: Additional Information	9
Figure 3: Indicum positioning template large.....	11
Figure 4: Indicum positioning template small	11
Figure 5: Indicum positioning - Mailing Item Address Label	12
Figure 6: Royal Mail Access Indicator sizes.....	13
Figure 7: format and positioning for return address - back	14
Figure 8: format and positioning for return address - front	14
Figure 9: Format split.....	17
Figure 10: Format + Service split	18
Figure 11: format + service + weight band split	18
Figure 12: Mixed Weight bag label	23
Figure 13: Mixed Weight York label.....	23
Figure 14: Mixed Weight.....	25
Figure 15: Bag label positioning guide.....	26
Figure 16: Bag label National and Zonal options.....	27
Figure 17: CFL bag size guide	28
Figure 18: Manifest	35
Figure 19: Summary Manifest	35
Figure 20: Multi customer Manifest	36
Figure 21: Waybill.....	37
Figure 22: York card.....	38
Figure 23: Segregation by format York card	39
Figure 24: York Manifest.....	39
Figure 25: Access Slots	43
Figure 26: Zonal indicator positioning.....	61
Figure 27: CFL requirements	66
Figure 28: Return address positioning.....	66
Figure 29: Annex A - KNP criteria.....	69
Figure 30: Annex B - KNP timeline.....	70
Figure 31: Annex C - KNP FTE.....	70
Figure 32: Zone definitions.....	71
Figure 33: Zonal Indicator positioning.....	72
Figure 34: Zonal Manifest.....	73

¹ Figures are not to scale.

Parcel Services for Inward Mail Centres

Explanation of Key Terms

This Wholesale Parcels User Guide (User Guide) is for the Wholesale Parcels Contract (Contract) and forms part of the contract under which Royal Mail Group Limited ('we' or 'us') will provide Parcels Services to Postal Operators and other users of postal services ('you').

If you have a current signed Contract with us, this User Guide confirms the basis on which your Mailing Items may be handed over and priced.

Your Contract offers a number of different sortation services. This User Guide details the presentation requirements and the specifications of all Services available under the Contract.

The Contract offers a national pricing option, an averaged pricing option or a Zonal pricing option ("Price Plan") as detailed in Schedule 3 of the Contract.

Definitions

Capitalised words in this User Guide have a particular meaning, either as defined in Schedule 1 of your Contract, a truncated copy of which is appended to this User Guide at [Appendix G](#), or as defined in the paragraph of this User Guide where it first appears.

1 Overview of Parcels Services

This User Guide must be read in conjunction with your Contract. Together these documents govern the terms on which you may obtain access to our Inward Mail Centres. Our Parcels Services enable you to hand over Mailing Items at an Inward Mail Centre which serves the Postcode carried by those Parcels and which are sorted by you to either:

- **1400** - Mailing Items sorted to c.1529 selections based on Postcode Districts
- **70** - Mailing Items sorted to c.86 selections based on Postcode Areas

Our Services offer different prices (referred to as "Charges") according to the sortation level and the machinability of your Mailing Items. All Services enable you hand over Mailing Items for delivery anywhere within the United Kingdom.

2 Key features and requirements

2.1 Service Standard

We aim to deliver or attempt to deliver Mailing Items on the next Working Day after handover to and acceptance by us.

2.2 Parcels Services Summary

Each Parcels Service requires you to sort, segregate and present Mailing Items at Inward Mail Centres in accordance with the Contract and this User Guide. The maximum weight for an individual Mailing Item is:

- 750g for A3 Parcels
- 2kg for Parcels

Figure 1: Summary of Parcel Services

Format	A3 Parcels		Parcel	Mail Sortation Required	Minimum Address and Postcode Accuracy Required
	0-750g	0-1kg		>1kg-2kg	
Weight Band					
Service					
1400	•	•	•	c.1529	90%
70	•	•	•	c.86	90%
Mixed Weight	•	•		Must match service used	

2.3 System Requirements

It is a requirement that the DocketHub (or any successor electronic billing system) system is used. DocketHub enables you to:

- upload Posting Dockets please see [section 9](#);
- provide Traffic Forecasting please see [section 11](#);
- make Access Slot Booking, please see [section 12](#);
- book Driver and Vehicle Registration please see [section 13](#).

It is recommended that approved Software be used to sort Mailing Items to the appropriate Parcels Services. A list of all approved Software suppliers can be found on our Website www.royalmailwholesale.com

2.4 Pricing options

There are three pricing options in the Contract:

National Price Plan One (SSC's)

A uniform Price Plan for meeting a posting profile equivalent to ours, as measured by the geographic spread and urban density of your Mailing Items to our Standard Selection Codes (SSC).

Averaged Price Plan Two (Zones)

A uniform Price Plan for meeting a posting profile equivalent to ours as measured by the geographic spread of your Mailing Items to our Zones.

Zonal Price Plan

Your Daily Postings are priced individually according to the number of Mailing Items for delivery in each pricing Zone.

Price Plans must be chosen by you and agreed by us before you enter into your Contract and you will then be given separate account numbers which you will need to use to identify whether your Mailings Items are being declared under the National Price Plan One (SSC's), the Averaged Price Plan Two (Zones) or the Zonal Price Plan.

2.5 Addressing Standards

You must ensure that the addressing standards set out in [Appendix A](#) are met. [Appendix A](#) provides information on what must be included in the address as a minimum and the address layout requirements. Please see [section 3](#) of this User Guide for the correct positioning of the Indicum and return address on a Mailing Item.

You must also ensure that each Mailing Item is addressed to its recipient so that the address is visible and legible at all times. For Zonal Postings there is an additional requirement to include the Zonal Indicator – please refer to [Appendix F](#).

2.6 Address and Postcode Accuracy

You must ensure that at least 90% of all Mailing Items are fully and accurately addressed and Postcoded in accordance with the Postcode Address File (PAF®).

For Postings for which you are required to denote the relevant Zone of the Mailing Items declared, where the address data on a Mailing Item does not have the Postcode selection in sufficient detail to identify a Zone, you must declare such Mailing Items as Zone Z, except for those Mailing Items whose delivery destinations are in the London Zone which you must declare as Zone D. The total number of Zone Z Mailing Items must not exceed 10% of your annual volume of Mailing Items posted within a Financial Year

You are responsible for uploading each Mailing Item to the correct Zone. The minimum Postcode accuracy for each UCID Posting or Consolidated Posting must be provided electronically via DocketHub or such other format as agreed by us. The Postcode must be consistent with the address stated according to PAF®.

Figure 2: Additional Information

Additional information	Links / Source of information	User Guide Reference.
The latest Access Selection Files for sorting national and zonal postings	Available from our Website www.royalmailwholesale.com	Appendix B
Downstream Access Customer Final Labelling (DSA CFL). This database is needed to create routing labels CFL's	Available from our Website www.royalmailwholesale.com The database includes routing information i.e. Inward Mail Centre addresses and latest Standard Selection Codes (SSC)	Section 7
DocketHub - Documentation & upload specification for posting Docket and Manifest forecasting, vehicle details and Access Slots.	Available from the Systems section on our Website www.DocketHub.com	Section 11
Approved Software Suppliers	Available from our Website www.royalmailwholesale.com which lists the software companies that have been approved to sort Mailing Items to the available Parcel Services.	Website

3 Indicum

Mailing Items will only be accepted at an Inward Mail Centre if they bear an Indicum approved by us. The Indicum cannot be used to access retail end-to-end services or for any other purpose than as set out in the relevant Contract and User Guide.

3.1 Indicum

All Mailing Items must carry an approved Indicum which has been agreed by us and you. The Indicum comprises:

The approved Customer Access Indicator (optional) – This must clearly and uniquely identify you or your carrier (where you use a carrier to handover Mailing Items to us at Inward Mail Centres) for example by including either:

- your legal entity name, or the legal entity name of your carrier; or
- a design registered by you or your carrier and
- a trade mark design registered to you or your carrier; and the Royal Mail Access Indicator, see Figure 6.

The Royal Mail Access Indicator - this must be used on any Mailing Item handed over under your Contract. The Royal Mail Access Indicator comprises the:

- the Royal Mail cruciform accompanied by the words 'Delivered by', and
- your unique Access Licence Number, which we will give you once a Credit Account has been set up for your Contract:

An example of the Indicum template to be used can be found at figures 3, 4 & 5. A copy of the actual Indicum template, which you must comply with, will be available to you (once your Credit Account has been set up) to download from on our Website www.royalmailwholesale.com. You must get our written approval for all designs and subsequent design changes. We require at least two months' written notice of design proposals prior to any requested implementation date. You may not use any designs before we have given you our written approval. This notice period allow us to carry out technical testing and other approval procedures.

In order for us to manage the operation of Parcels Services in a liberalised marketplace with many customers you will be limited to a maximum of 5 different designs for your Indicum, which can be used for the Contract, unless we agree otherwise. Negative versions (i.e. a reverse image e.g. white on black) of current approved positive images of your Indicum are not classed as additional Indicum designs, and are included within the maximum 5 designs allowed. These negative images must be tested and agreed as acceptable in writing us before they can be accepted on Mailing Items.

The Indicum can be printed on the outer of the Mailing Item or on an address label which is then applied to the outer of the Mailing Item.

Figure 3: Indicium positioning template large

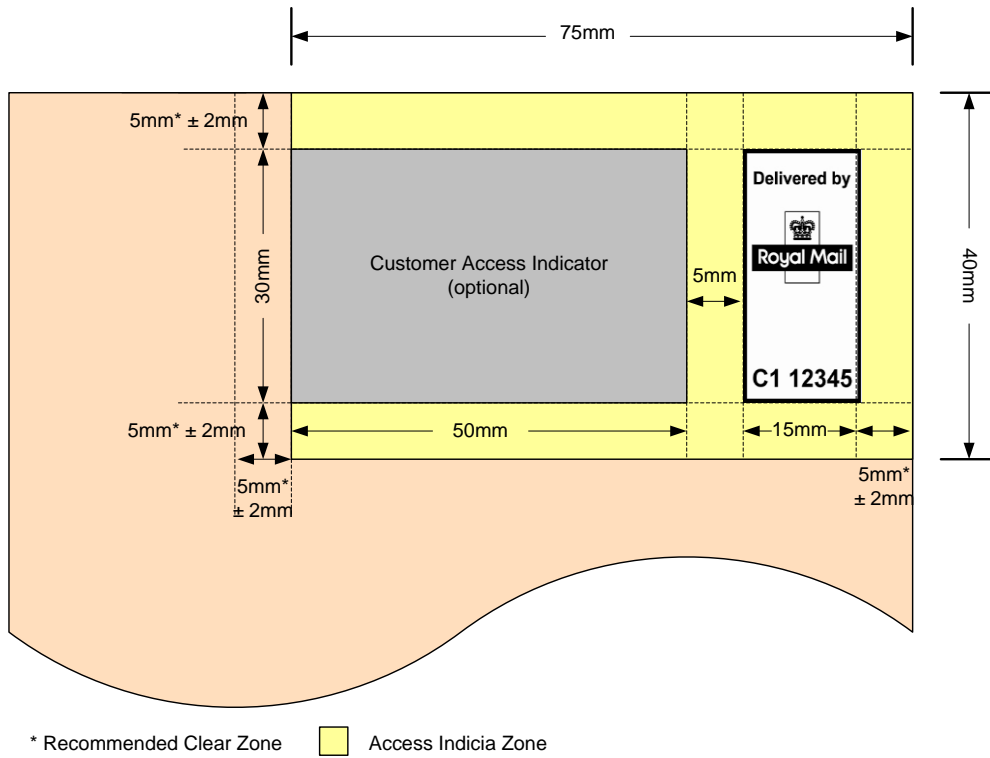

Figure 4: Indicium positioning template small

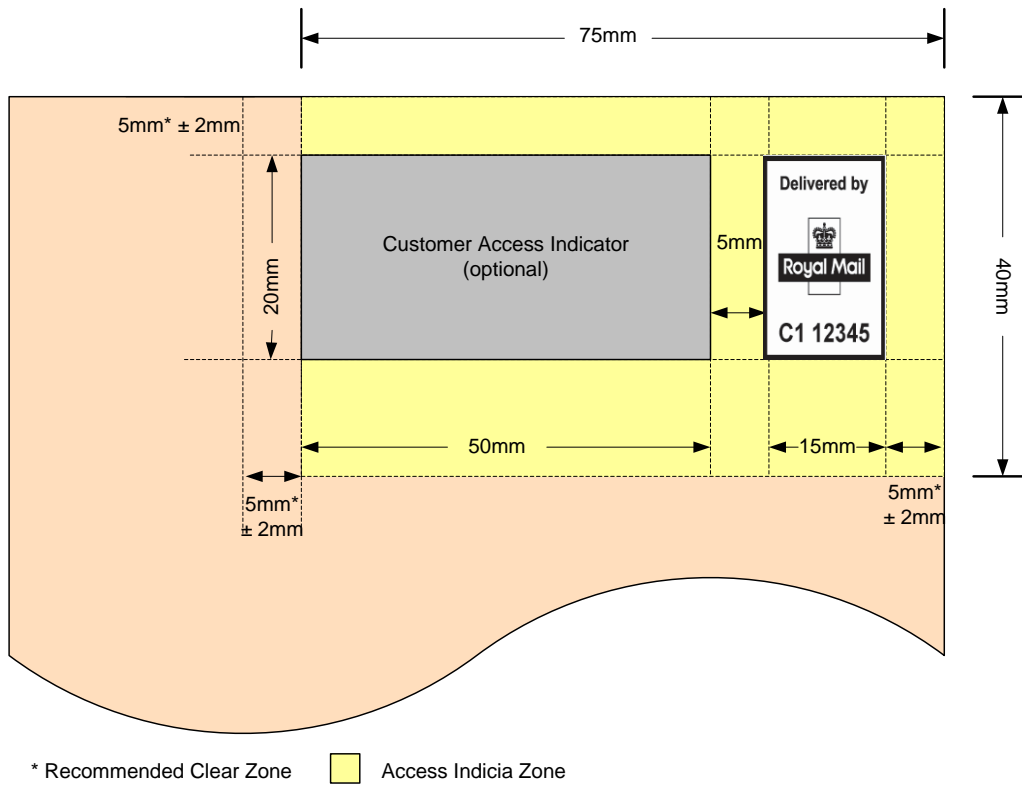

Figure 5: Indicium positioning – Mailing Item Address Label

(Large Indicium design. The small Indicium design can also be used in this way.)



The top and right hand edge of the Indicium zone (as set out in figures 3, 4 and 5) must be aligned exactly to the top and right hand edges of the Mailing Item or Mailing Item address label on which the Indicium is printed. The preferred clear zone round the Indicium is 5mm². There is no minimum clear zone.

For irregular shaped Mailing Items please contact your Access Account Director for preferred Indicium positioning.

Upon setting up a Credit Account you will be issued with a unique Access Licence Number for use on all Mailing Items. This unique Access Licence Number will be incorporated within the Royal Mail Access Indicator for use by you. Mailing Items will not be accepted unless all Mailing

² We will allow a tolerance of $\pm 2\text{mm}$ movement within the 5mm to account for print processes

Items include your Access Licence Number. Mailing Items carrying any other Indicum or the Indicum of another customer may not be posted under this Contract.



The Indicum must be printed in accordance with the design specification as detailed in the templates in figures 3, 4, and 5.

3.2 Indicum Size

Royal Mail Access Indicator

You may choose either of the specified sizes for the Royal Mail Access Indicator to use for your Mailing Items.

Figure 6: Royal Mail Access Indicator sizes

Large	Small
30mm tall & 15mm wide 	20mm tall & 15 mm wide 

Customer Access Indicator

- Large Customer Indicator - Maximum area available is 30mm tall x 50mm wide
- Small Customer Indicator - Maximum area available is 20mm tall x 50mm wide

There is no minimum size for the Customer Access Indicator but it needs to be visible and any words used to clearly and uniquely identify you need to be in a font that is at least 10 points.

Any variation in size or design from that submitted by you will need to be checked before use.

3.3 Stamp-like Indicum

Included as one of the 5 approved Indicum, you also have the option of creating a stamp-like Indicum which may be printed as an image on to the Mailing Item or can be applied as a self-adhesive label. The stamp-like Indicum must include the Royal Mail Access Indicator as shown in figure 6 and be approved prior to being accepted. Full details of the stamp-like Indicum specification can be found on our Website www.royalmailwholesale.com and your Access Account Director will be able to provide further information.

3.4 Return Addresses and Undeliverable Mail

You shall ensure that every Mailing Item is clearly marked on the reverse with a United Kingdom³ return to sender address (please refer to [Appendix A](#) for more information on addressing standards). Figure 7 shows the recommended format and positioning of the return

³ For the avoidance of doubt, the Channel Islands or the Isle of Man are not part of the United Kingdom, and there is no obligation by Royal Mail to repatriate Parcels to non-United Kingdom addresses. Therefore Royal Mail Wholesale does not accept the use of addresses based in these islands for the purposes of the return address requirements of the Parcels Contract

address for all Mailing Items. This should be left justified and should be preceded with the words 'Return Address'.

Figure 7: format and positioning for return address – back

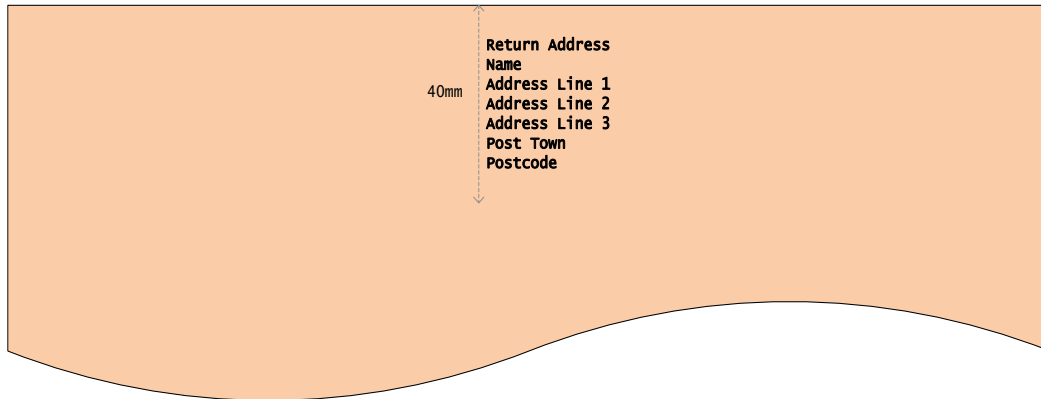

The positioning of the return to sender address on the reverse of a Mailing Item is to minimise confusion with the Delivery Address. Where it is not possible to print the return to sender address on the reverse e.g. in a polybag, on a polywrap or it is part of the Mailing Item address label, the return to sender address may be printed in accordance with figure 8.

Figure 8: format and positioning for return address - front



ROYAL MAIL WHOLESALE

Any undeliverable Mailing Items may be returned to the United Kingdom return to sender address provided on the Mailing Item.

The use of a PO Box within the return to sender address is optional. If you choose to use a PO Box you can apply for a PO Box on the Royal Mail Website (please note that charges apply): www.royalmail.com

In accordance with the Postal Services Act 2011, our obligation is to deliver to every United Kingdom address each Working Day (Monday to Saturday). This obligation does not extend to providing a breakdown of Mailing Items by chosen identifiers including, departments, teams, floors at the Delivery Address so that it is ready for internal delivery at that address. If you require return mail to be pre-sorted for example by department, we may provide a Selectapost service, at standard rates, which enables you to have Mailing Items pre-sorted to chosen identifiers prior to delivery. This service, however, is subject to local operational capability.

It is your responsibility to ensure that you comply with our return to sender address format and position on the Mailing Item.

4 Enquiries & Complaints

Should we receive enquiries/complaints from recipients of Mailing Items (the addressee) sent under your Contract, the addressee will be advised to contact you (except where the issue concerns delivery procedures e.g. mis-delivery when we will deal directly with the recipient).

Should we receive enquiries/complaints from any third party for whom you have posted Mailing Items under your Contract, they will be advised to contact you.

Any issue that you wish to discuss in relation to the Contract should be raised in the first instance with your Access Account Director. Any complaint about service or operational issues should be raised in the first instance with DSACC. (DSACC@royalmail.com)

5 Preparing Mailing Items

5.1 Step 1: Format Segregation

Each Daily Posting and UCID Posting or Consolidated Posting may be split by format into A3 Parcels or Parcels and only contain Mailing Items accepted under the terms of the Contract.

If you choose not to split your Mailing Items by format then all Mailing Items must be presented and declared as Parcels.

Figure 9: Format split

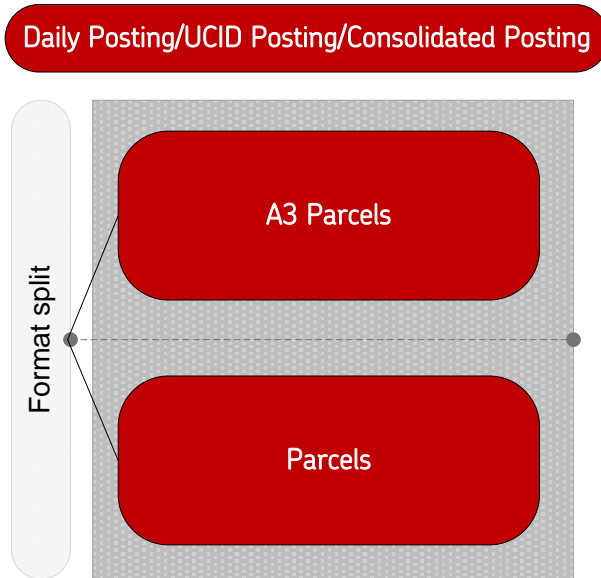

Each Mailing Item must comply with the physical parameters for the appropriate format which are: (or as otherwise specified by us from time to time.)

- A3 Parcel - format which is
 - Maximum size 420mm x 297mm; and
 - Maximum thickness 25mm; and
 - Maximum weight 750g
- Parcel – format which is
 - more than 750g; or,
 - larger than 420mm x 297mm; or,
 - thicker than 25mm; and
 - the maximum dimensions if rectangular, are no larger than 610mm x 460mm x 460mm and, if cylindrical, has a maximum length of 900mm and the Parcel length when added to twice the diameter does not exceed 1040mm.
 - Parcels must weigh no more than 2kg.

The size definition of a Mailing Item for length and width excludes plastic outer covers, provided that they are flimsy and easily folded, in which case the outer packaging will not count in relation to how the format of the Mailing Item is priced.

5.2 Step 2: Sortation split

Each Mailing Item must be sorted according to one of the Parcels Services as stated in [section 2.2](#), in accordance with this User Guide and you must use the current Version of the Access Selection Files provided (see [Appendix B](#)). We will provide at least one month's prior notice of any changes to the Access Selection Files coming into effect.

Sortation to - 1400

Mailing Items are sorted to the level of Postcode Districts – these are called the Selections. The Access Selection Files contain around 1529 of these Selections.

Where Mailing Items sorted to 1400 Selections are being produced and there are insufficient Mailing Items to meet the minimum Container fill requirements (i.e. more than one Under Volume Container is being produced) you should consider bringing the Mailing Items together at a 70 sortation level in order to achieve minimum Container fill or use software to dynamically fill each Container.

Sortation to - 70

Mailing Items are sorted to a level which is based on Postcode Areas – these are called the Selections. The Access Selection Files contain around 86 of these Selections.

Figure 10: Format + Service split

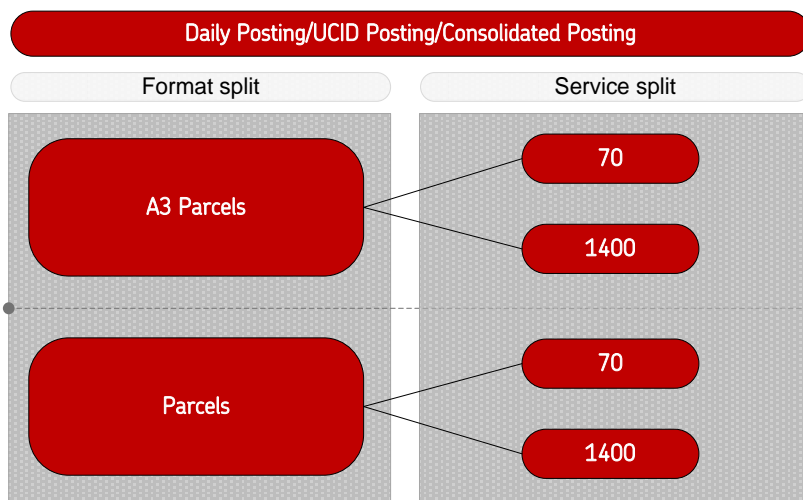

5.3 Step 3: Weight Band Segregation

Mailing Items within a Daily Posting and UCID Posting or Consolidated Posting may be split between format (A3 Parcels and Parcels as defined in [section 5.1](#)) and Service (70 and 1400 as defined in [section 2.2](#)). In addition, if you post Mailing Items of varying weights, Mailing Items must also be sorted into the correct weight band depending on the format and Service of the Mailing Item.

Figure 11: format + service + weight band split

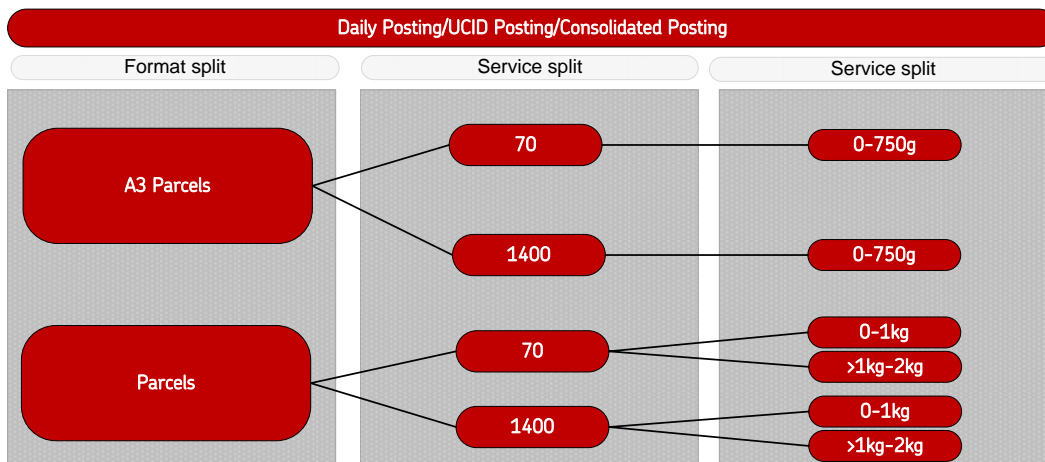

6 Sortation & Presentation

You must present Mailing Items in an approved Container. The choice and type of Containers permitted for Mailing Item presentation are:

- Bag
- Auto Level Packet Sleeve (ALPS). These must be used in conjunction with Yorks and you must sign both the Yorks and ALPS Schedules prior to use.

6.1 Minimum Container Fills (Bags, ALPS)

Minimum Container Fills - Each Container may only contain only A3 Parcels or Parcels.

In the case of A3 Parcels each bag or ALPS shall contain at least:

5 A3 Parcels each weighing no more than 750g.

In the case of Parcels each bag or ALPS shall contain at least:

- 5 Parcels each weighing no more than 1kg; or
- 5 Parcels each weighing more than 1kg and no more than 2kg

6.2 Under Volume Containers (Bags, ALPS)

An Under Volume Container is a Container that does not contain the minimum number of Mailing Items in each weight step as defined in [section 6.1](#)

6.2.1 Unique Customer Identifier (UCID) Postings

You have the option of using a Unique Customer Identifier (UCID) on your Container Labels. This is an identifying number (maximum 15 characters) created and assigned by you that uniquely identifies each of your discrete Customer Entities, Posting Entities and Originating Customers which allows you to associate Mailing Items relating to each separate entity/customer. The numbering methodology for UCIDs must be submitted and approved by us before use. If you wish to use UCIDs you must complete Schedule 4 of your Contract to submit your proposed UCID numbering methodology for approval by us.

Where a UCID is assigned to a Customer Entity, Posting Entity or Originating Customer, each time you hand over Mailing Items for a particular entity/Customer, the same unique UCID must be used. It is mandatory for that UCID to remain unchanged throughout the life of the Contract, except if you have our approval to make changes.

Where a valid UCID is used, we will restrict the corrective actions we may take under Schedule 2 of the Contract and section 15 of this User Guide against any Mailing Items we find during Revenue Protection which do not comply with the terms of your Contract and this User Guide to those Mailing Items bearing the same UCID.

If you fail to use a UCID in accordance with the terms of your Contract and this User Guide, you will lose the right for your UCID to be recognised for the purposes of Revenue Protection. Where you present a UCID Posting in accordance with Schedule 2 of your Contract and this User Guide then one Under Volume Container per Standard Selection Code (SSC) per UCID per Service used per day will be charged at the Charges relevant for that Service. This is subject to all other terms and conditions being met.

Any additional Under Volume Containers will be charged as follows:

- A3 Parcels & Parcels - First Class Advertising Mail Packet High Sort residue

Where we have agreed to your numbering methodology for UCID Postings and UCID numbers are being used, for each Container relating to the same UCID Posting, the same UCID number must be visible within the customer ID field of the Customer Final Label (CFL) (see [section 7](#)) and correspond with the UCID number on the Manifest.

6.2.2 Selecting the relevant Under Volume Container to be charged.

Where more than one Under Volume Container is produced, DocketHub (or other systems we may develop and make available) will select the Under Volume Container per SSC per Service that will be charged at the relevant Charge on the basis of the following:

- the Under Volume Container per SSC with the greatest number of Mailing Items; or
- where two or more Under Volume Containers have the same number of Mailing Items, the Container with the highest average item weight.

All additional Under Volume Containers are to be charged as detailed in [section 6.2](#) and must be declared as such on the Manifest and Posting Docket.

You shall ensure that the Container fill per SSC is maximised subject to the need to meet the requirement that each Container of Mailing Items presented must have the item contents accurately recorded on the Manifest and correspond to the Container's UCID.

6.3 Presenting your Mailing Items in Bags

6.3.1 Bundling Mailing Items

Mailing Items of a similar weight, shape or size must be bundled securely within bags. The number of Mailing Items in each bundle will depend on the nature of the Mailing Items, which will normally be determined by their size and thickness. Each Selection may consist of a number of bundles. Each individual Mailing Item must be securely sealed.

There is no required minimum number of Mailing Items in a bundle as long as the segregation criteria has been met as set out above, but as many Mailing Items as possible must be included within each bundle (subject to the maximum Container weight). There is no maximum limit to the number of Mailing Items included in a bundle provided they do not exceed the maximum weight limit of the Container in which the bundle is then placed, and the thickness of the bundle does not exceed that which can be held in one hand (approximately 15cm).

All bundles must be tied with the Mailing Items facing the same way, using sufficient strapping or rubber bands, so that they do not burst open in the bag, given reasonable handling conditions. If Mailing Items are 'wedge-shaped', they should be counter-stacked with the top half facing the opposite way to the bottom half.

Once the tie or strapping have been removed the Mailing Items must be capable of being handled individually and must not be stuck to one another for any reason, including any stuck together due to the use of any adhesive in the mail production process. Mailing Items should be bundled in such a way as to not damage the individual Mailing Items or others in the same bag.

Bundles that become insecure as a result of inadequate strapping or other material used will be subject to Surcharges.

There is no requirement to bundle Parcels when presented in Containers as it is accepted that the physical dimensions and weight of individual Parcels may mean they are not suited to being bundled therefore Parcels can be placed loose in to each Container.

6.3.2 Bagging Mailing Items

The maximum bag weight accepted by us is 11kg, including the weight of the bag, bag tie and label. Depending on the volume you are posting, more than one bag for a SSC may be needed. To make sure the bag weight will not exceed 11kg, it may be necessary to mark the bag breaks on the Mailing Items.

You must ensure that all Mailing Items for a single SSC are included in one bag unless the maximum weight of the bag is exceeded. Where possible all Mailing Items within each bag should be of a similar weight, shape or size. You must ensure that more than one bag is used if

the weight of a bag, bag tie and label exceeds 11kg. The bag neck should be securely tied using bag ties we will provide. Bags must not be tied through the 'D' rings.

The minimum number of Mailing Items accepted in a bag is 5 as set out in [section 6.1](#). In general, however, bag fill must be maximised and filled to capacity within the SSC, subject to meeting accurate bag fill.

To determine when a new bag must be started and a new label provided, you will need to distinguish where the Mailing Items for one SSC ends and a new SSC begins. There are a variety of ways to do this e.g. Print the SSC near the address; this determines that it is time for new bag when the code changes. Software can be set up to print a distinguishing mark (e.g. three asterisks) on the last item for each bag in each SSC, or work through the printout of its sorted mailing list and mark it by hand. You can produce a blank label as a SSC break indicator between each Selection.

It is recommended that the long tail ends and loose ends of bag ties are tucked and wrapped into the band formed by the bag ties to prevent it sticking out and causing injury to anyone handling the bags.

A Mailing Item that cannot fit into our standard sized mail bag due to the physical dimensions of it, or up to 5 Mailing Items are unable to fit into our standard sized bag due to the combined physical dimensions, may be presented in ALPS (subject to you having an ALPS Schedule as part of your Contract with us). Please contact DSACC if you do not have ALPS but encounter this exceptional issue.

6.4 Presenting your Mailing Items in ALPS

If you have entered into an ALPS Schedule as part of your Contract with us, ALPS may be used for the purpose of handing over Mailing Items under this Contract as more particularly described in the ALPS Schedule.

6.4.1 Bundling Mailing Items

Mailing Items must be placed loose in to each ALPS as it is accepted that the physical dimensions and weight of individual Mailing Items may mean they are not suited to being bundled and we sort individual Mailing Items direct from each ALPS. Each individual Mailing Item must be securely sealed.

6.4.2 Mailing Items in ALPS

Like bags an ALPS is a primary Container. Therefore the same requirements for sortation, labelling and maximising fill (i.e. accurate number of Mailing Items/Under Volume Charges), applies as for bags. See [section 6.1](#).

Each Container shall contain only Mailing Items for a single SSC. SSCs must not be mixed within a Container. Efficient use of ALPS Containers is a requirement that is to the benefit of both you and us. Consequently, for any single SSC, a Container must be full before another Container is used for the same SSC unless the maximum York weight of 250kg is exceeded. ALPS Containers must be fully zipped up and secured when presented at the Inward Mail Centre.

Mailing Items to Jersey (JE), Guernsey (GY), Isle Of Man (IM) are excluded from being presented in ALPS for security and safety reasons and must be presented in bags in accordance with [section 6.3](#). A Mailing Item for Jersey, Guernsey or Isle of Man that cannot fit into our standard sized mail bag due to the physical dimensions of it must be presented and labelled as an individual Container.

6.4.3 Labelling Requirements

For Mailing Items posted in Containers, a bag CFL, as defined in [section 7](#), or if Mixed Weight in [section 6.8](#), must be securely attached to a blank York card, which is secured in the York label holder.

6.5 Unwrapped Bundle Postings

Some Mailing Items may be presented in either bags or ALPS as unwrapped. Please refer to [Appendix C](#): Unwrapped specification for full details.

6.6 Unbagged Bundle Postings

Some Mailing Items may be presented as unbagged bundles. Please see to [Appendix D](#) for full details relating to this specification.

6.7 Unwrapped and Unbagged bundle mailing.

Some Mailing Items may be presented as unwrapped and unbagged. Please see both [Appendix C & Appendix D](#) for full details relating to Mailing Items presented in this way.

6.8 Presenting Mailing Items as Mixed Weight

Mixed Weight is a presentation option that you may choose, subject to signing a Mixed Weight Schedule and completing the implementation timeline. Please ensure you plan in sufficient time to fully deploy the Mixed Weight presentation option. Your Access Account Director will be able to advise of the timescales involved. Mixed Weight enables you to handover Mailing Items at an Inward Mail Centre and combines different weight bands in one Container.

Mixed Weight Daily Posting documentation is submitted to us via the web service DocketHub. You are required to test the upload interface via DocketHub prior to posting a Mixed Weight Posting. The Service Standard and other service criteria for Mixed Weight Postings are as already specified within the main body and Appendices of this User Guide.

6.8.1 Mixing Weight Bands

Where all of the individual Mailing Item weights in a Container comprise a mix of weight bands ('Mixed Weight') you must declare on the Manifest the total number of Mailing Items by weight band, and the zone if applicable (please refer to [Appendix F](#) for more information on Zonal Postings). Please see figure 14 for an example Mixed Weight Manifest.

The weight band indicators to be used on the Manifest are as follows:

Parcels

- WB1 (weight band 1) - Mailing Items weighing no more than 1kg. All Mailing Items falling within this weight band will be priced accordingly.
- WB2 (weight band 2) - Mailing Items weighing more than 1kg and no more than 2kg. All Mailing Items are priced in 250g increments at the average weight of all items falling within this weight band.

Where all the Mailing Item weights in a Container fall within a single weight band the Mailing Items must be declared as such on the Manifest and will be priced accordingly. Where an entire Daily Posting does not contain any Mixed Weight Containers you must declare and upload the Daily Posting using your non-Mixed Weight account in the usual way.

6.8.2 Labelling Requirements

For the Mixed Weight presentation option, there is a requirement to include an additional identifier (MW) on the Container CFL. This identifies to the accepting Inward Mail Centre that the Posting is Mixed Weight. See figure 12.

If your Mailing Items arrive in York Containers, there is also a requirement to include 'Mixed Weight' on the York cards. See figure 13.

. All other labelling requirements are as [section 7](#) of this User Guide

Figure 12: Mixed Weight bag label

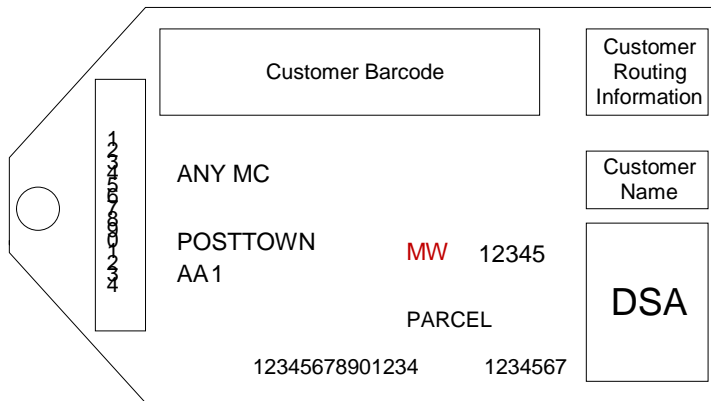
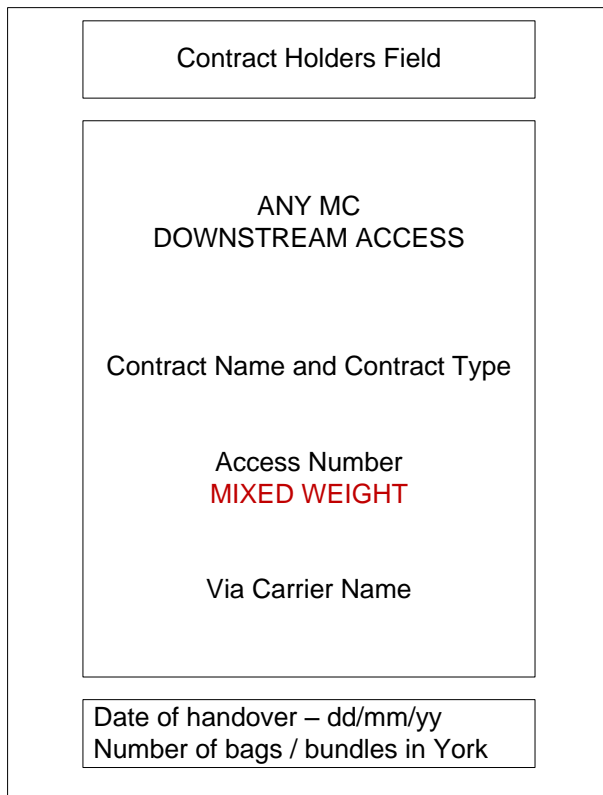

Figure 13: Mixed Weight York label



6.8.3 Documentation

For Mixed Weight Mailing Items your Manifest, must be uploaded electronically to DocketHub, and received no later than 06:30am on the Handover Day of the Mailing Items to which the Manifest refers. You will be issued with a separate discrete account number for use of Manifest uploads to DocketHub, this will be allocated as part of the implementation timeline.

The Manifest enables you to declare Mixed Weight Containers and non-Mixed Weight Containers within a Mixed Weight Daily Posting. In addition, two physical copies of either the Summary Manifest or the Manifest must accompany Mixed Weight Mailing Items handed over at an Inward Mail Centre.

The Manifest data for a Mixed Weight Container must declare the number of Mailing Items within each weight band and show the average weight of the Mailing Items for Parcels in WB2 and the total weight of the Mailing Items in the Container.

For Mailing Items posted under National Price Plan One (SSC's) or Averaged Price Plan Two (Zones) the data must be populated with the volume of Mailing Items under the 'National' column (NAT) for each weight band (an example is shown in blue text on the Manifest at figure 14). For a non-Mixed Weight Container within a Mixed Weight Daily Posting, you must declare the number of Mailing Items by weight band and show the total weight of the Mailing Items in the Container and the average item weight (an example is shown in black text on the Manifest at Figure 14.)

For Postings under a Zonal Price Plan, the data must also include the number of Mailing Items by zone within each weight band. (An example declaring Zonal Mixed Weights is shown in red text on the Manifest at figure 14). For a non-Mixed Weight Container for Zonal Mailing Items you must also declare on the Manifest the number of Mailing Items by zone within a weight band. (An example declaring a non-Mixed Weight Container for a Zonal Mailing Item is shown in green text on the Manifest at figure 14)

6.8.4 Pricing.

Each Mixed Weight Daily Posting is priced according to the number of Mailing Items within each weight band.. For Parcels in WB2 prices are calculated according to the number of Mailing Items at the average weight falling within this weight band.

ROYAL MAIL WHOLESALE

Figure 14: Manifest for Mixed Weight Postings

I/MC I/MC Address: Job reference:	Date of handover to Royal Mail dd/mm/yy Account number: Posting Docket number: Sheet X of X																						
Individual Bag Identification																							
Container ID No.	Originating Customer No.	SSC	Postcode Area	No. Items WB1						No. Items WB2						Avg Weight (WB2)	Actual Total Weight (kg)	Average Weight of Mailing Items (g)	Total Mailing Items (units)	Format	Service	Sortation	
				N A T	A	B	C	D	Z	N A T	A	B	C	D	Z								
12345678	ABCDEF	123	XX	X							X						X	X	X	X	Parcel	Mail	70
12345679	ABCDEG	123	XX	X													X	X	X	X	Parcel	Mail	1400
1234567D	ABCDEH	123	XX		X	X	X					X	X	X	X		X	X	X	X	Parcel	Mail	1400
1234567E	ABCDEH	123	XX		X	X	X										X	X	X	X	Parcel	Mail	1400
1234567F	ABCDEH	123	XX		X	X	X	X			X	X	X				X	X	X	X	Parcel	Mail	1400
1234567G	ABCDEH	124	XX					X									X	X	X	X	Parcel	Mail	1400
		Total No. of Containers	Totals																				
Delivery note: This delivery note does not constitute that the above details are correct, as these details will be subject to Royal Mail revenue protection checks. For the avoidance of doubt, this document only acknowledges the handover of Large Letters on a time and date specified.																							
For Royal Mail use only.																							
For customer use only																							

7 Customer Final Labelling Requirements

Containers must be labelled with Customer Final Labels (CFL), which indicate the destination and contents of the Container and include the information as specified by us.

We will provide blank labels to you; only these labels may be used to produce final labels and these final labels may only be used for the final Containerisation, labelling and sealing of Containers prior to handover to us (rough labelling will not be accepted). Only white CFL's are to be used on Containers.

7.1 Label Positioning Guide

Figure 15 shows the dimensions and area for use by you within the CFL.

Figure 15: Bag label positioning guide

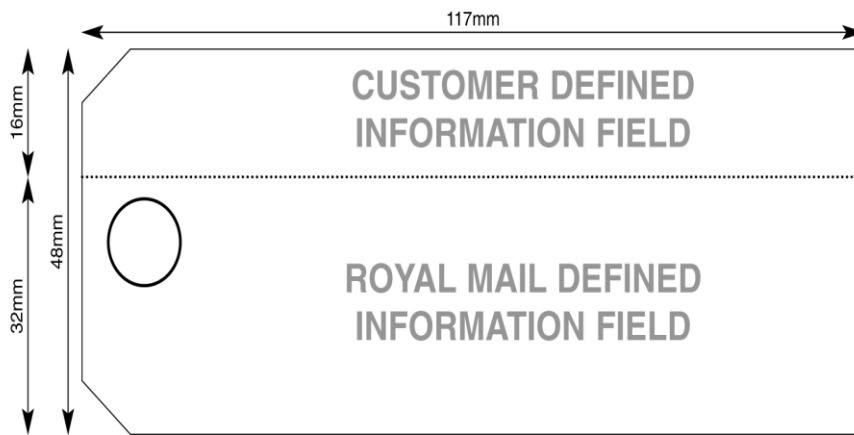

7.2 Customer defined information field

The customer defined information field within the CFL is for your routing or other required information. The label design and any subsequent changes to the defined customer defined information field require two months' prior written notice for approval from us before use. This is to avoid the potential for operational confusion. You must send hard copy proofs to your Access Account Director for approval prior to use.

7.3 Royal Mail defined information field

The Royal Mail defined information field is where you must include all the relevant information we require in order for you to route and handover the Container to the correct IMC.

Figure 16 are examples of what a CFL looks like, including specifications for field size, fonts and formatting. Please note all fields are aligned left, unless otherwise stated.

Where you have entered into a separate ALPS Schedule for Mailing Items posted in ALPS Containers, you must label each ALPS by securing the CFL to a blank York card, which is secured in the York label holder.

Figure 16: Bag label National and Zonal options

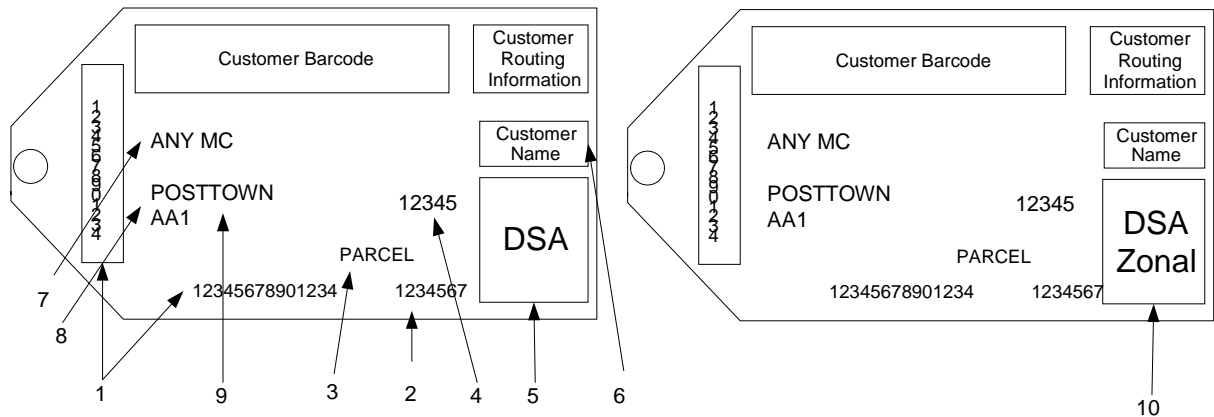

- 1. Unique Container Identification Number** - This is an identifying number unique to that Container (maximum of 14 characters). The same unique number is to be printed on the Manifest against the description of that Container's contents. It is optional whether you want to repeat the unique Container ID on the vertical axis as illustrated in figure 16
- 2. Unique /Customer Identification Number** – (UCID). Use is subject to our approval of your numbering methodology via the inclusion of Schedule 4 to your Contract. This is an optional identifying number (maximum 15 characters) assigned by you to each of your discrete Posting Entities, Customer Entities or Originating Customers. Where a UCID is assigned, each time you hand over Mailing Items for the same Posting Entity, Customer Entity or Originating Customer, the same unique UCID number must be used.
- 3. Format** – This indicates the Mailing Items within the Container and shall always be in uppercase:
 - PARCELS PARCELS
 - A3 PARCELS A3 PRCL
- 4. Standard Selection Code (SSC)** – The SSC for the Selection name as per the Access Selection Files.
- 5. Customer type indicator** – This is optional - it indicates the type of customer you are:
 - DSA by operators (where you are the carrier for another operator who has their own Contract, it is optional for 'DSA' to be followed by the last 3 digits of their access Licence Number.)
 - CDA for customer direct access. CDA is then followed by the last 3 digits of your access Licence Number.
- 6. Customer Name** – The name of the customer or your Access Licence Number.
- 7. Destination Office** - The destination office is the Inward Mail Centre at which the Container is to be handed over.
- 8. Selection Name** –The name of the Selection as listed in the Access Selection File. This is only applicable for 1400 Selections.
- 9. Selection Description** - This field defines the Postcode group within the Container and this information can be obtained from the CFL database:
 - For 1400 Selections – this is Postcode District (or Sector)

- For 70 Selections - this is the Postcode Area (or District) followed by the word 'RESIDUE' or 'RES'
10. **Zonal Indicator** – The identifier 'Zonal' must be included on the CFL. The recommended positioning is to place this to the right of the CFL and it must be clear and legible and a minimum point size of 10.

7.4 Size Guide

The following two tables provide a guide as to the font size and relative font width of the CFL characteristics.

Figure 17: CFL bag size guide

BAGS			
Characteristic	Font Size (Helvetica and Ariel are both acceptable)	Font height	Maximum no of characters
Unique Bag Identification Number	11pt Arial Bold	3mm	14
UCID	11pt Arial Bold	3mm	15
Format	13pt Arial Bold	4mm	15
Customer Name	11pt Arial Bold	3mm	
Customer Type indicator	28pt Arial Bold (DSA) 21 Arial Bold (DSA/XXX) 21 Arial Bold (CDA/XXX)	12mm (DSA) 6mm DSA/XXX) 6mm (CDA/XXX)	(DSA) 3+3 DSA/XXX) 3+3 (CDA/XXX)
Destination Office	17pt Arial Bold	7mm	25
Selection Name	14pt Arial Bold	5mm	25
Standard Selection Code	14pt Arial Bold	5mm	5
Selection Description	14pt Arial Bold	5mm	14
Database Version Indicator (optional)	10 pt Helvetica Bold Oriented 90 degrees	3mm	3
Zonal Indicator	Minimum 10pt Arial	3mm	5
Mixed Weight Identifier	17pt Arial Bold	7mm	2

7.5 Producing Customer Final Labels

There are two methods you can use to carry out your Customer Final Labelling.

7.5.1 Using label printers

If you are a large business, you may wish to use a label printer which could be used in one of the following two ways:

- **On Demand** - this allows you to generate your own labels according to your specific needs, by keying in the relevant Standard Selection Code (SSC)
- **Batch File Processing** – label printing machines can also be used in a batch processing mode by either, manually keying in label requirements in advance from a printed list or computer disk or driving the printer directly from your computer system.

7.5.2 Database method

We provide you with a label database containing the necessary geographic routing information to enable accurate labelling. You will, however, need to purchase or develop your own software to work with the database in order to produce the correct CFL.

7.6 The different Labelling methods explained

There are a number of ways to perform your labelling operations. This section takes each method in turn and examines the areas you need to take into account, to ensure the whole process runs smoothly.

7.6.1 Final label printers

This is probably the most efficient option for larger-scale labelling operations. If this is the method you decide to use, you first need to decide whether to run the machine on-line or off-line. This will depend on a number of factors:

- The number of production lines in use at any one time
- The type of mailing
- The type of environment (both the computer and printer will operate more efficiently in a clean environment)

To operate it off-line, in batch mode, you will first need to decide whether to key each batch of SSCs manually via an electronic process, or directly from your computer system.

7.6.2 Database method

There are two main areas you need to consider if implementing this method: your production process and computer systems.

Production process - we will supply you with blank labels and plastic ties or to tie your bags.

Computer systems - we will provide you with test data and implementation guidelines (available from your Access Account Director). You will then need to perform the programming required to provide access to the CFL database, and the capability of the printer to produce labels meeting our specifications.

7.7 Contingency plan

Whichever method you choose, you should draft an appropriate contingency plan to implement in case the main system should fail.

7.8 Chosen Labelling Method

Once you've decided on which labelling method you might want to use, the first thing to do is to contact your Access Account Director, who will help you to work out your specific requirements.

If you choose the database option, you'll also need to produce a set of test labels for us to check before you can fully implement and print CFL's.

7.9 Data formats

It is a requirement to use the correct and current CFL database. The latest Version of the CFL file is available to download from our Website www.royalmailwholesale.com.

File layout

DSAMANFL.DAT – is the CFL file required for producing CFL's for manual mail, i.e. Parcels or A3 Parcels.

ROYAL MAIL WHOLESALE

The DSAMAN.DAT file contains a record for each SSC, laid out as follows:

Field	Size	Type	Comments
Database Version ID	3	Numeric	1 st digit represents version 2 nd /3 rd digit represents release
Destination Office ID	3	Numeric	Unique identifier for each Mail Centre
Standard Selection Code	5	Numeric	Unique identifier for sortation selections
Destination Office	30	Alphabetic	Mail Centre Name
Selection Name	30	Alphabetic	Only applicable for 1400 Selections. (Delivery Office Name)
Selection Description	30	Alphanumeric	1400 Postcode District (or Sector) 70 Postcode Area (or District) followed by the word 'RESIDUE' or 'RES'. followed by the word 'RESIDUE' or 'RES'
Total	101		Record Length

DSADESTNL.DAT - contains a record for each Inward Mail Centre together with address details, laid out as follows:

Field	Size	Type	Comments
Database Version ID	3	Numeric	1st digit represents version 2nd/3rd digit represents release
Destination Office ID	3	Numeric	Unique identifier for each Mail Centre
Destination Office Name	30	Alphabetic	Mail Centre Name
Address Line1	40	Alphabetic	1st line of the Mail Centre address
Address Line2	40	Alphabetic	2nd line of the Mail Centre address
Address Town	40	Alphabetic	Mail Centre Post Town
Postcode	8	Alphanumeric	Mail Centre Postcode
Total	204		Record Length

8 Equipment for Postings

8.1 Blank Labels and Bag Ties

We will make available and supply blank CFL's and bag ties to you as you may reasonably request via a scheduled monthly supply based on your average monthly Container use. This volume will be reviewed regularly to track the average monthly usage. Where additional ad-hoc consumables are required you must give DSACC (DSACC@royalmail.com) 5 Working Days' notice of your requirements and we will use reasonable efforts to provide your required amounts within the notice period. We provide blank labels and bag ties which must be used for final containerisation, labelling and sealing prior to handover to us. You shall only order blank labels and bag ties from DSACC and these will be delivered to your nominated address as detailed in the L.O.R. Consumables will be supplied in multiples of the appropriate box fills. We will not provide any other consumable items, such as rubber bands and bundle ties.

8.2 Bags

We will make available and supply to you as you may reasonably request mailbags from Inward Mail Centres on a daily basis using a pre agreed site/volume schedule. The schedule will be reviewed regularly, tracking the average monthly bag usage and availability of bags in the Inward Mail Centres. Where additional bags are required you must provide at least 5 Working Days' notice to DSACC of the required amounts. For requests for more than 100,000 bags a week at least 10 Working Days' notice must be given to DSACC. Ad-hoc bags will be collected by you from wherever the bags can be obtained within the notice period. Our bags must only be used for the final bagging process prior to handover to the Inward Mail Centre. Empty bags must be collected from our specified site(s) at a time agreed by both you and DSACC.

We do not supply Yorks for the transportation of empty bags; if you require bags supplied in Yorks, you must provide enough of your own Yorks for the bags required. Alternatively, you can loose load bags. It is your responsibility to safely load the vehicle.

Should you wish to introduce your own, wheeled, braked container that can be nested for the purpose of bag collection, we will need to carry out a national risk assessment on the container followed by a local risk assessment and we will need to be trained in its use. You must provide a container and details of Safe Systems of Work for the container type. The purpose of the assessments is to determine if the container is acceptable for the sale collection of bags and the associated processes.

8.3 Yorks/Auto Level Packet Sleeved (ALPS)

We will not supply York and or ALPS Containers to you unless it is operationally mutually beneficial to do so. You may purchase Yorks and ALPS from our preferred suppliers, provided that each proposed purchase is notified in advance to us via the signing of the relevant York Exchange Schedule or ALPS Schedule. Alternative arrangements can be made to hire our Yorks on a short term ad-hoc basis via signing the York Hire Schedule. Whether supplied or purchased, York and ALPS Containers must only be used in accordance with the relevant York Exchange or Hire Schedule or ALPS Schedule available to download from our Website www.royalmailwholesale.com

Once such arrangements have been completed we will operate a one-for-one exchange of Yorks and ALPS with you, at each Inward Mail Centre at which you handover Mailing Items. This process must be supported by an accurate waybill for audit trail purposes. To allow for work in progress (i.e. the Containers in transit and Containers being filled), you will typically need to purchase Yorks/ALPS in a ratio of 3:1 to cover peak volume usage.

If you use your own Containers, you must unload all Mailing Items from your Containers at the point of handover to us. We will supply suitable Containers at the point of handover for you to place Mailing Items into.

All requests for Yorks or ALPS should be notified to DSACC as soon as possible but no less than 7 Working Days prior to the posting for which they are required in conjunction with the pre-notification process (please see [section 11.](#))

8.4 Property

Blank CFIs, bag ties, mail bags, Yorks and ALPS (and any other such property we may introduce from time to time) shall remain our property at all times.

When handing over Mailing Items to us you shall only use property supplied by us in accordance with this User Guide and the Contract. You shall return all property to us upon termination of your Contract or otherwise as we may reasonably request. You shall keep the property in the safe custody and in reasonably good condition allowing for reasonable wear and tear.

Property referred to in this section shall not be used by you or any 3rd party suppliers for any other purpose than carrying out your obligations of this User Guide and your Contract and property must only be used to enable the handover of Mailing Items to one of our Inward Mail Centres.

We shall be entitled to inspect such property referred to in this section at any reasonable time and in the case of misuse of the property by you, your customers or 3rd party suppliers may repossess such property acting reasonably.

9 Documentation

9.1 Posting Dockets

You must supply a Posting Docket in respect of each Daily Posting. The Posting Docket is used to calculate the Charges that will be invoiced to you and it must accurately record the Daily Posting.

Posting Dockets and supporting data to enable the creation of Manifests must be submitted electronically to DSACC (DSACC@royalmail.com) using our DocketHub system (or other system that we may develop and make available), and, after processing by DocketHub, confirmed and received by DSACC no later than 06:30am on the Handover Day of the Mailing Items to which the Posting Docket refers

To enable you to use DocketHub, please refer to the External Webservice technical specification document which is available for download in PDF format on our Website www.royalmailwholesale.com.

Should additional information be required, please contact DSACC in the first instance.

The Posting Docket must represent the sum of the information provided in the Manifests, and will be automatically generated by DocketHub. A Manifest is required for each Inward Mail Centre accessed for each Posting and may be produced by manual input into DocketHub, or by electronic interface with mailing software.

9.2 Contingency arrangements

In the unlikely event you are unable to produce a Posting Docket electronically, we will accept as an interim contingency arrangement a submission via DocketHub or an alternative system solution approved by us, provided you have prior agreement with DSACC.

9.3 Calculating Charges

DocketHub will automatically calculate the indicative Charges for the Posting Dockets with the final values confirmed via our invoice. This is because DocketHub holds the Charges to a different decimal place level to our invoicing system which creates small discrepancies due to rounding up.

Where an alternative system solution approved by us is being used, you shall calculate the Postage in accordance with Schedule 3 of your Contract and for each Daily Posting shall provide full and accurate details of that calculation and Daily Posting in the Manifests to us in accordance with this User Guide.

9.4 Manifests

A Manifest (see figure 18) is your declaration of the details of the Posting to be handed over by you to each Inward Mail Centre. Please see [Appendix E](#) for Key National Posting (KNP) Manifest requirements. Your data that creates each Manifest must be submitted and confirmed by you electronically via DocketHub to DSACC no later than 06:30am on the Handover Day. In addition, two physical copies of either the Summary Manifest (please see figure 19) or the Manifest must accompany Postings handed over at an Inward Mail Centre.

During exceptional circumstances and with the prior agreement of DSACC, alternative arrangements for submission of Manifest information to DSACC may be made.

If you have Schedule 12: Acceptance By Vehicle included in your Contract, in addition to the Manifest, you are required to upload a Vehicle Manifest in to DocketHub and provide two physical copies of the Summary Vehicle Manifest when you hand over the Mailing Items at an Inward Mail Centre. This Summary Vehicle Manifest is in place of the Summary Manifest

The Manifest will:

- allow us to verify that Mailing Items have been presented in accordance with your obligations under the Contract and that the Posting Docket(s) details reflect the Postings and/or Daily Posting; and
- provide confirmation that some Mailing Items were handed over to an Inward Mail Centre. Two copies of the Summary Manifest or the Manifest will be signed, timed and dated by us after your vehicle is unloaded. One copy will be retained by you as a delivery note, and the other, by the Inward Mail Centre.

The handover of Mailing Items and the signing of the Manifest does not constitute acceptance of the Mailing Items by us. Acceptance of Mailing Items by us only occurs after Revenue Protection has taken place and any issues have been resolved in accordance with the provisions of Section 15 of this User Guide and Schedule 2 of the Contract. A Posting will be deemed to have been accepted by us within one Working Day from handover by you unless we have raised any issues about the Posting with you.

The Manifest must accurately represent the contents of each Container and must contain the following information:

1. Account name
2. The Access Site (Inward Mail Centre being accessed)
3. The Access Site address
4. The Handover date
5. Your account number
6. Your Posting Docket number
7. Your Access Licence Number
8. Details of each INDIVIDUAL CONTAINER must be listed on a single line including:
 - A unique Container identification number – that corresponds to the same number on the CFL
 - A UCID – if relevant that corresponds to the same UCID on the CFL
 - Standard Selection Code – The SSC within the current Access Selection Files for the relevant selection.
 - Postcode Area – The first alpha character(s) of the Postcode - i.e. G for Glasgow Postcodes and PO for Portsmouth Postcodes.
 - Product Code Details
 - Zone – For postings on a National Price Plan this will be 'NAT'
 - Number of Mailing Items in each Container
 - Average Mailing Item weight
 - Total weight of Mailing Items – Excluding the weight of the Container, label and bag tie
 - Declared Container weight
 - Declared Container Items
 -

Where a Zonal Posting is being made, the Manifest must also include the numbers of Mailing Items for each zone contained within each Container (See [Appendix F](#) for more information).

Figure 18: the Manifest

Site Manifest / Delivery Note																						
IMC						Date of handover to Royal Mail dd/mm/yy																
IMC Address::						Account number:																
Job reference:						Posting Docket number:																
						Sheet X of X																
Individual Bag Identification																						
Container ID no.	Originating Customer No.	SSC	Postcode A B A	No. Items UWB1						No. Items UWB2						Average Weight UWB2	Actual Total Weight (kg)	Average Weight of Mailing Items (g)	Total Mailing Items (unit)	Format	Service	Sortation
				N	A	B	C	D	Z	N	A	B	C	D	Z							
12345678	ABCDEF	123	XX	X						X						X	X	X	Parcel	Normal	70	
12345679	ABCDEG	123	XX	X												X	X	X	Parcel	Normal	1400	
		Total No. of Containers	Total																			
Delivery note: This delivery note does not constitute that the above details are correct, as these details will be subject to Royal Mail revenue protection checks. For the avoidance of doubt, this document only acknowledges the handover of Large Letters on a time and date specified.														For Royal Mail use only.								
For customer use only																						

Figure 19: Summary Manifest

Single Customer

Customer name:					
Site Manifest / Delivery note.					
IMC:			Date of handover to Royal Mail: dd/mm/yy		
IMC:			Account number:		
IMC address:			Posting Docket:		
			Licence Number: C9 XXXXX		
Job reference:			Sheet X of X		
Total Bags (declarations + exceptions)			Total ALPS* (declarations + exceptions)		
1	Number of bags on the system upload		5	Number of ALPS on the system upload	
2	Number of exceptions - bags removed from the system upload		6	Number of exceptions - ALPS removed from the system upload	
3	Number of exceptions - bags additions on the system upload		7	Number of exceptions - ALPS additions on the system upload	
4	Total number of bags presented (total=1-2+3)		8	Total number of ALPS presented for 1: 4: 1 swaps (total=5-6+7)	
			9	Total Yorks* Total number of Yorks presented for 1: 4: 1 swaps	
* to be populated only when you have signed the relevant Container Agreement					
Delivery note: this delivery note does not constitute acceptance that the above details are correct as these details will be subject to Royal Mail revenue protection. For the avoidance of doubt this document only acknowledges the handover of Parcels on the time and date specified.					
Royal Mail:			Royal Mail use only:		
Customer use only:					

ROYAL MAIL WHOLESALE

Figure 20: Multi customer Manifest

Carrier name: IMC:		Date of handover to Royal Mail dd/mm/yy Sheet X of X					
Name of Contract holder	Customer A	Customer B	Customer C				
Account number							
Posting Docket							
Licence Number: C9 XXXXX							
Total number of bags Including net effect of + and - exceptions							
Total number of ALPS Including net effect of + and - exceptions							
Total number of bags, ALPS Including net effect of + and - exceptions							
<p>Delivery Note: This delivery note does not constitute acceptance that the above details are correct, as these details will be subject to Royal Mail revenue protection checks. For the avoidance of doubt, this document only acknowledges the handover of mail items on the time and date specified.</p> <p>Signature of Royal Mail For Royal Mail use only Date of handover:</p> <p>Print name: Arrival time at Royal Mail:</p> <p>Signature of carrier: For customer use only</p> <p>Print name:</p>							

9.5 Agreeing the Client Report

Each day DSACC will generate an email message to inform you that the Client Report is available to view within DocketHub. The Client Report enables us and you to agree the adjustments made to Posting Docket. The Posting Docket cannot be approved until agreement is received from you and you must do this promptly and in any case within 2 hours of receipt of the Client Report. The Client Report comprises of a summary report and other supporting information, e.g. Under Volume Containers and mis-sorts. Once the Client Report is approved, the Daily Posting is released for processing. There are two exceptions to this arrangement:

- (i) when there are no adjustments to your declared Daily Posting, we will automatically release the Mailing Items for processing rather than wait for you to approve the Client Report; or
- (ii) if you have agreed to the Early Release Schedule as part of your Contract.

9.6 Early Release Schedule

This Contract allows us automatically to release your Mailing Items once Revenue Protection has been completed rather than wait for the Client Report to be sent to you. This enables earlier processing of your Mailing Items. For full details speak to your Access Account Director or download the Early Release Schedule from our Website www.royalmailwholesale.com.

9.7 Waybill documentation

Where an appropriate Yorks or ALPS Schedule has been agreed as part of your Contract which allows you to use these Containers for the handover of Mailing Items, it is necessary for a waybill to be provided. The waybill controls the volume of Containers in use and supports the one for one exchange of Containers in line with the relevant Container Schedule. Example of a waybill can be found in figure 21

If you have Schedule 12: Acceptance By Vehicle included in your Contract, you do not need to provide us with a separate waybill as it is incorporated in to your Summary Vehicle Manifest.

Figure 21: Waybill

Downstream Access Container Waybill			
Customer Name			
Mail Centre Name:			
Container Type	Handover	Returned	Balance
Yorks (1)			
Bags			
ALPS			
(1) Ensure Yorks used to return ALPS are included in York returned figure - should not exceed handover figure			
RM Name		Driver Name	
RM Signature		Driver Signature	
Date		Date	

9.8 York card documentation

Where an appropriate York Exchange or Hire Schedule has been signed to allow the use of Yorks for the handover of Containers, it is necessary for each York to have clearly and visibly displayed a York card. The information contained within the York card enables the accurate and efficient handling of your Daily Posting. Example of a York card can be found in figure 22.

Figure 22: York card

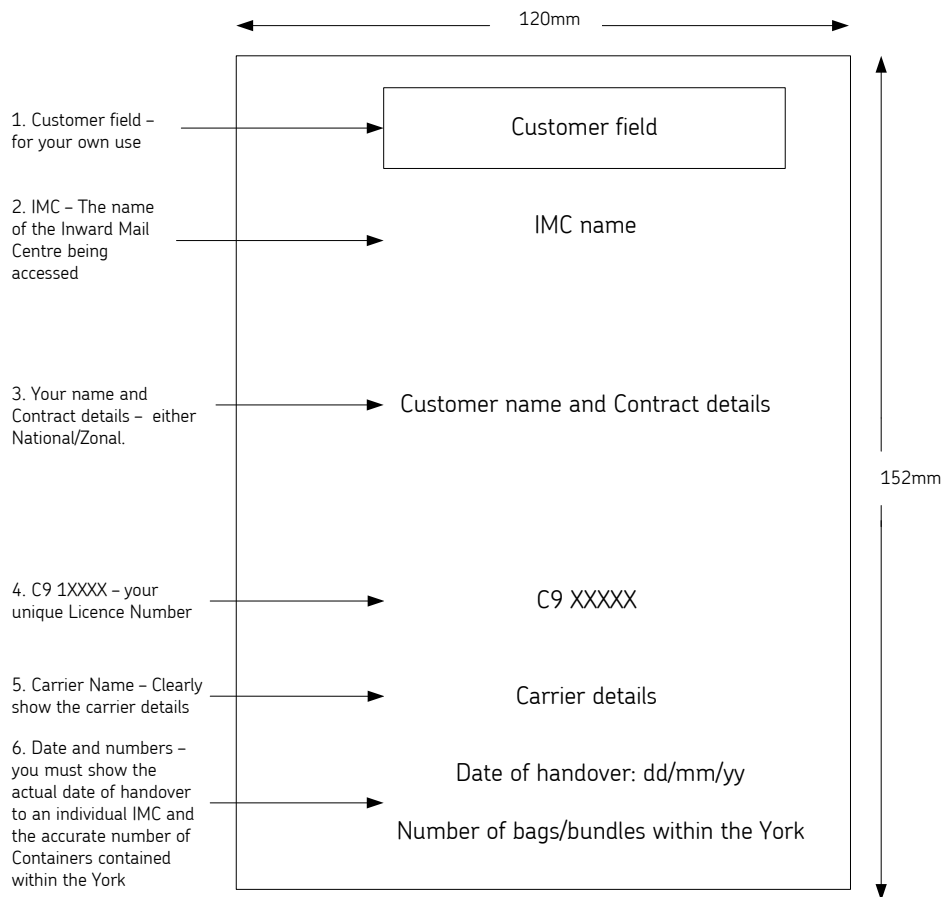

9.9 Segregation by Format York card documentation

If you have agreed to the 'Segregation By Format' Schedule as part of your Contract (details can be found on our Website www.royalmailwholesale.com) and are required under the terms of that Contract to submit an accurate York Manifest (please see [section 9.10](#)), it is necessary for each York to have clearly and visibly displayed the following information on a York card:

Figure 23: Segregation by format York card

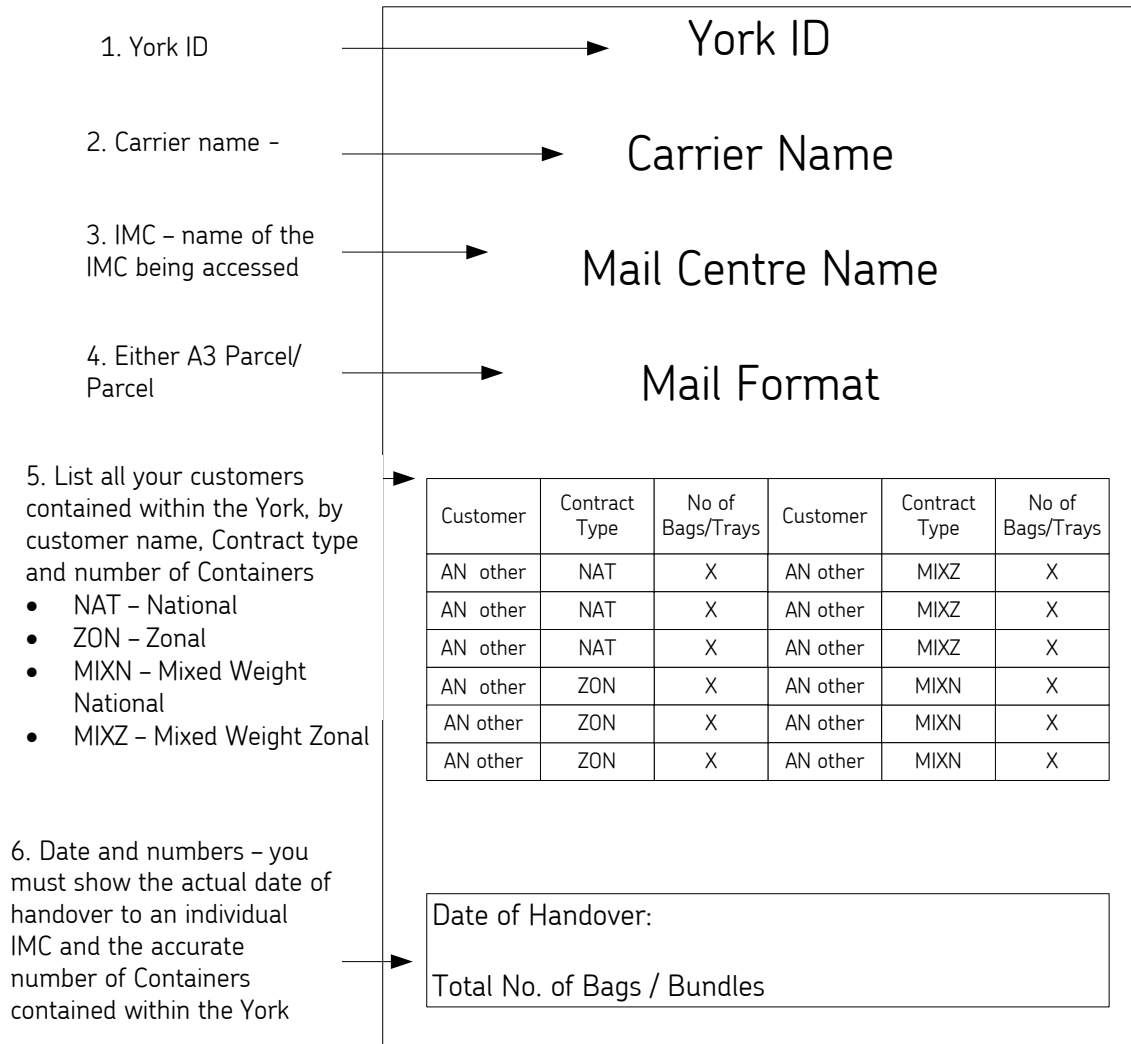

9.10 York Manifest

If you have agreed to a 'Segregation By Format' Schedule as part of your Contract and are required under the terms of that Schedule to submit an accurate York Manifest, figure 24 illustrates the minimum information that is required on the York Manifest.

The York Manifest must be presented in a CSV file format, or such other format as specified by us from time to time, and must be sent electronically to us by no later than 08:00am on each Handover Day. If Exceptions have been uploaded by you, creating a possible error to the 08:00 York Manifest, a second and final accurate York Manifest must be sent electronically to us by no later than 10:15am on each Handover Day.

Figure 24: York Manifest

Mail Centre (DSADE STN)	UCID	Customer Name	Account Number	Contract Type	Format	York ID	No of Containers

10 Calculating the Postage

This section provides an overview for the process for calculating the Charges for Mailing Items segregated in accordance with [section 5](#).

10.1 Postage for Mailing Items in weight band 1 (WB1)

Format	WB1	Pricing
A3 Parcel	0 and no more than 750g	constant price
Parcel	0g and no more than 1000g	constant price

The Postage for Mailing Items is calculated by multiplying the total number of Mailing Items by the relevant per Mailing Item Charge relevant to the format and Service.

Postage = Total number of Mailing Items x per Mailing Item Charge for the format at the relevant Service.

10.2 Postage for Mailing Items in weight band 2 (WB2)

Format	WB2 – Within WB2 there are 4 price steps relevant to the weight breaks below.				Pricing
Parcel	1001g - 1250g	1251g - 1500g	1501g - 1750g	1751g - 2000g	Variable price calculated on average weight of Mailing Items per Container.

Calculating the Access Charge

Step One: In order to calculate the Charges for Mailing Items, the average weight per Mailing Item will first need to be calculated for each Container as follows:

$$\frac{\text{Total weight of Mailing Items}}{\text{Total number of Mailing Items}} = \text{Average weight per Mailing Item}$$

Step Two: The Mailing Item Charge is the pricing step applicable to the average weight per Mailing Item e.g. Average Weight 1800g = price displayed on the Website for Mailing Items 1751g - 2000g.

11 Despatching the Posting

11.1 Pre - Notification of Posting

There are three stages to advising us of your intention to handover a Daily Posting. All stages must be submitted to us via the DocketHub web service provided . This is designed to enable us to ensure sufficient staff and other resources are to hand to meet the Service Standard. The three stages that you must comply with are:

- Stage 1: 7 day rolling forecast
- Stage 2: Pre-notification
- Stage 3: 06:30am (on Handover Day) Posting Docket and Manifest(s)

Technical specifications for and DocketHub can be found on our Website www.royalmailwholesale.com

11.2 7 Working Day Rolling Forecast

You must provide DSACC (DSACC@royalmail.com) by 10:00am each Working Day with a daily rolling forecast of your posting intentions over the following 7 Working Days. If you do not intend to handover Mailing Items each Working Day then you must populate the 7 Working Day rolling forecast on the relevant day(s) with '0'.

Each day's forecast will include your anticipated volume of Mailing Items for handover at each Inward Mail Centre. This forecast must be sent electronically via the web service provided by us 'DocketHub' or other systems as we may make available and in the format specified in the technical specifications on the DocketHub website via a link on our Website www.royalmailwholesale.com

11.3 Pre-notification

You must provide DSACC with pre-notification by 10:00am each Working Day of the Postings you intend to hand over the next Working Day.

The pre-notification must detail as accurately as possible the volume of Mailing Items for the handover the following Working Day at each Inward Mail Centre. This forecast must be sent electronically via the web service provided by our 'DocketHub' or other systems as we may make available and in a format specified in the technical specifications on the DocketHub website via a link on our Website www.royalmailwholesale.com.

For those customers who have developed processes that generate a more accurate version of their 10:00 Pre-notification, you may provide us with an additional Pre-notification by no later than 16:00 each Working Day of the Postings you intend to hand over on the next Working Day. For clarity, any reforecast Pre-notification you provide us by 16:00 will be accepted as fulfilling the contractual requirement that you provide us a Pre-notification before Handover Day. Where you provide us with a later (i.e. by 16:00) Pre-notification, we shall measure and use the accuracy of the later Pre-notification for performance measurement purposes against the contract requirement for accuracy. Where no later (by 16:00) reforecast Pre-notification is supplied, accuracy will continue to be measured using the 10:00 Pre-notification

11.4 06:30am Posting Docket and Manifests

You must provide DSACC with confirmation of the details of the Mailing Items that are actually handed over by you at each Inward Mail Centre during that Working Day's Access Slot. This consists of a Manifest for each Inward Mail Centre, which when totalled make up the Daily Posting and form the content for the Posting Docket. This must be sent electronically via DocketHub and be confirmed by you and received by DSACC after processing by DocketHub no later than 06:30am on the Handover Day to us.

11.5 Forecast for Key National Postings (KNP)

Some postings will be of a significant size, weight, shape or geographic bias that it is necessary to apply additional planning so the operational requirements for managing and successfully delivering such a posting are achieved. Where you have identified potential postings of this nature to us, and we have agreed that a particular posting will have an operational impact of some degree, it is classed as a Key National Posting (KNP). The details of what constitutes a Key National Posting (KNP) can be found in [Appendix E](#). Regular meetings with your Access Account Director will be used to discuss your future planned posting volumes and help recognise when Mailing Items need to be managed as a KNP.

Where you have a KNP, we will already be aware of the format of the Mailing Items and whether they are Machinable or Manual Mailing Items from the information provided by you at the monthly meetings, but you must provide DSACC with formal notification of each KNP at the following times:

- (i) by 10:00am on 7 Working Days prior to (each) Handover Day, an estimate of the volume of Mailing Items and the breakdown to each Selection;
- (ii) by 10:00am on 24 hours' notice prior to (each) Handover Day, as accurate as possible, the number of Mailing Items and the breakdown to each Selection; and
- (iii) by 06:30am on Handover Day, a Posting Docket and Manifests accurately detailing the volume of Mailing Items to each Selection.

The breakdown you must provide with each of the 7 days' and 24 hours' forecasts, (or sooner if it available) is the fall to earth (FTE) of the Mailing Items and details extra information to the number of Mailing Items for each Selection. The FTE provides invaluable information on the KNP and enables you and us to align resource and / or consumables where necessary to ensure the Service Standard can be achieved. Typically you will be able to provide FTE information using the output data report from the sortation software you use to sort the Mailing Items to the desired Service, known as the line listing. As a minimum the line listing will detail the number of Mailing Items per Container by SSC, destination name and format. Where possible, for Mailing Items sorted to the 70 Service the breakdown of Mailing Items to Postcode Districts should still be provided. The FTE is to be provided to DSACC electronically in EXCEL or other appropriate format as agreed by DSACC, (until such time as we make available an electronic upload facility). The FTE should match the details that you have provided for the 7 Working Day forecast.

12 Access Times

12.1 Access Windows

Daily Postings must be handed over at Inward Mail Centres during the Access Window. The Access Window is Monday to Saturday 07:30am to 12:00pm on any Working Day.

12.2 Access Slots

You must book an Access Slot for handover of Mailing Items at each Inward Mail Centre. The Access Slot is a 30 minute time period within the Access Window, during which you must begin handover. You must use reasonable endeavours to complete unloading of your vehicle within 30 minutes of the time at which you began.

Figure 25: Access Slots

Access Slots	Access Slots	Access Slots
07:30 – 08:00	09:00 – 09:30	10:30 – 11:00
07:45 – 08:15	09:15 – 09:45	10:45 – 11:15
08:00 – 08:30	09:30 – 10:00	11:00 – 11:30
08:15 – 08:45	09:45 – 10:15	11:15 – 11:45
08:30 – 09:00	10:00 – 10:30	11:30 – 12:00
08:45 – 09:15	10:15 – 10:45	

12.3 Access Slot Change Request Process

The aim of this process is to ensure that requests for new or changes to existing Access Slots are managed in a controlled way. All requests and notification of changes to Access Slots are to be made via DocketHub.

Within three months of the start of your Parcels Start Date we will consider reasonable requests to change your Access Slots. After this initial period you may request a change to the timing of your Access Slots up to 4 times per Inward Mail Centre per annum. Any requests for changes to Access Slots must be made via DocketHub and we may require at least 14 Working Days for change requests to be processed. DSACC will either confirm in writing that the Access Slot is available, or if it is not, offer an alternative where available. Whilst we will use every effort to meet your requirements, this may not be possible in every instance. The final decision regarding the allocation of Access Slots rests with us.

You must use your existing Access Slot until such time as we have confirmed any Access Slot changes in writing.

In instances of Mail Centre consolidation, Royal Mail will use reasonable efforts to continue to meet your requirements at the Inward Mail Centre affected by the change but may require you to change your Access Slot or, in cases of multi vehicle use, to accept more than one Access Slot.

12.4 Ad-hoc & Additional Access Slot Booking Process

If you are on the Zonal Price Plan you may book an Ad-hoc Access Slot via DocketHub. An Ad-hoc Access Slot is an Access Slot which is only required for a limited period at any Inward Mail Centre. Similarly Customers who are either on National Price Plan One (SSC's) or Averaged Price Plan Two (Zones) may book additional slots at particular Inward Mail Centres should volumes warrant. The process for booking these Ad-hoc or additional Access Slots is as follows:

- you must provide at least 10 Working Days' notice of implementation at a new Inward Mail Centre;
- you must provide at least 2 Working Days' notice of booking an Access Slot for an Inward Mail Centre which you had previously accessed;

- you must notify a request to DSACC (DSACC@royalmail.com) via DocketHub by 12 midday, 2 Working Days before the required slot and be followed by a back-up telephone call to DSACC, which must also be made by 12 midday 2 Working Days before the Access Slot. If for reasons of operational capacity or capability, we are unable to accommodate such an ad-hoc Access Slot request, we may refuse your request;
- a 7 Working Days forecast ahead of the requested slot should be entered on to the system whenever possible;
- this facility is not available for Key National Posting (KNP) arrangements detailed at [Appendix E](#);
- you must provide a minimum of 2 Working Days' notice of Access Slots and driver and vehicle details and these are to be uploaded into DocketHub. This must also be confirmed by telephone to DSACC;
- you must specify the lifespan for the ad-hoc or additional Access Slot from one day up to a maximum of 1 calendar month period. Ad-hoc or additional Access Slots will be booked on a 'first come first served' basis. Once the lifespan of the Access Slot has elapsed the Access Slot will be released for other Customers to use. We reserve the right to withdraw the ad-hoc facility and raise any reasonable charges if we believe you are misusing the facility; and.
- You must provide volume forecasts, pre-notification and Manifest as per [section 11](#) and consumable ordering as per [section 8](#).

12.5 Multiple Vehicles per Access Slot

If you need to use more than one vehicle to bring in your Mailing Items in to your pre-booked Access Slot, due to the volume of Mailing Items, you must notify DSACC at least 2 Working Days in advance via email stating the number of vehicles you intend to use. For all additional vehicles the current driver and vehicle requirements as detailed in [section 13](#), must be complied with.

If you need to use double deck trailers, you must notify DSACC and get their agreement before their use is permitted.

13 Handover

You shall co-operate with all reasonable requests by us in relation to security issues.

13.1 Security Procedures

You must supply DSACC (DSACC@royalmail.com) with an up-to-date list of all driver names and vehicle registrations that will visit each Inward Mail Centre. There is a maximum of 15 driver names and 15 vehicles per Inward Mail Centre in order to manage volumes going forward. This information must be supplied and maintained using the web based service provided by us through 'DocketHub'.

On arrival at the Inward Mail Centre, we will check the driver's identity badge (which must carry a photograph) and vehicle registration against the list supplied by you. You or your carrier will be required to provide an example of their photographic identity badge (or that of a chosen third party carrier) to DSACC in electronic format. We will refuse access to any driver or vehicle whose details do not appear on the list, unless contingency arrangements have been agreed by DSACC.

You must ensure that any changes to the list (names, vehicles and effective dates) are actioned through 'DocketHub' no less than 48 hours in advance of the change coming into effect. As a contingency, we will allow access to an Inward Mail Centre for a non-listed driver and/or vehicle subject to you providing DSACC with at least one hour's prior notification by fax or e-mail of the details of the non-listed driver/vehicle. Your driver must carry a letter of authority in a format agreed by us to verify their details.

13.2 Health and Safety

We will provide you with details of our Health and Safety requirements including any site-specific health and safety requirements and you will be required to ensure that all your employees and agents comply with such health and safety requirements.

As a minimum, we will require all drivers to wear toe-protecting safety shoes and high visibility jackets whilst on our premises. All drivers must also comply with all our on-site traffic rules. All drivers will only have access to the areas of the Inward Mail Centre directly related to the handover of Mailing Items. Drivers must not enter any other areas e.g. sorting hall and staff restaurant.

All drivers must follow any health and safety instruction given by any of our employees.



RMW HS

Requirements v3.pdf

13.3 Dock Allocation

On arrival at the Inward Mail Centre, one of our employees will direct the driver to the appropriate unloading dock. If the dock area is busy, our employees will ask the driver to wait until the dock has been cleared before the vehicle is unloaded.

13.4 Unloading & Handover

Each Daily Posting is, independent of any other Daily Posting. Where you hand over Daily Postings on behalf of other Contract holders, the Daily Posting must not be mixed and segregation of different Daily Postings must be maintained. Each Daily Posting must be clearly identified by indicating whether it is a National or Zonal Daily Posting on the York card (if a York Schedule has been signed).

For information on unloading a KNP please see [Appendix E](#)

Your driver must unload your Mailing Items in to our Containers when and where directed by our employees; this will facilitate Revenue Protection against your Mailing Items. Where you use Yorks, your driver is responsible for unloading/reloading the Yorks when and where directed by our employees.

All Mailing Items handed over to an Inward Mail Centre must be accompanied by two hard copies of the Manifest. (Due to the amount of paper used for the printing of a full Manifest, it is preferable to use a Summary Manifest format for this purpose). These Manifests must not be placed inside Containers. At handover one of our employees will sign, time and date both copies of the Manifest. Note that this procedure does not represent acceptance of the Posting in terms of volume, formats, or contents; it simply acknowledges that a quantity of items has been handed over. We and your driver will each retain one copy of the Manifest.

13.5 Amalgamation of discrete Daily Postings in Yorks

Where you hand over Daily Postings on behalf of other Contract holders and hand over Containers in Yorks and you wish to amalgamate Containers from different Daily Postings in the same York, you may do so provided:

- they are presented in accordance with the requirements of this [section 13.4](#)
- each York has an attached cage card specifying the number of Containers by customer in each York; and
- you undertake all reasonable efforts to ensure that the Mailing Items combined in a single York are not unnecessarily mixed i.e. separation by a layer of cardboard or some other effective means.

13.6 Exiting the Site

Once the vehicle has been unloaded by your driver, your driver must move the vehicle away from the dock as soon as practicable (whilst observing the speed limit) and leave the site as directed by our employees.

13.7 Contingency

In the event of an Inward Mail Centre being inaccessible for any reason our contingency plans will apply. DSACC will notify you of alternative arrangements and any subsequent change or reversion to normal practice as soon as is practicable.

14 Revenue Protection

We reserve the right to sample Mailing Items received from you to verify that your Postage declaration is accurate and to ensure that you comply with the terms of your Contract including this User Guide. These are referred to as 'Revenue Protection Checks'. Incorrect declarations and any other non-compliances will result in us taking action in accordance with the Procedures for Handling Non-compliant Postings, set out in [section 15](#). Where sampling gives a statistically valid result by format, by Service, and where used, by UCID to Daily Posting levels, then we reserve the right to adjust the Postings in line with those results to either the Posting level, or the Daily Posting level.

15 Procedures for Handling Non-compliant Postings

If having sampled your Mailing Items we have identified that Mailing Items fail to comply with the required terms of this Contract, we shall notify you (including by telephone or electronically) as soon as is reasonably practicable after identifying the error but no later than within 24 hours. Mailing Items deemed to be non-compliant may be automatically excluded from the Service Standard calculation referred to in Schedule 2 of the Contract. We will hold the Mailing Items pending agreeing a resolution to the issue with you for up to 24 hours. We will invite you to inspect the Mailing Items at the Inward Mail Centres where they have been identified. If following your inspection (or the expiry of the 24 hour period, whichever the sooner) we remain satisfied that there has been a non-compliance, we may proceed to implement the procedures within this Section.

We will not undertake any rectification action until such time as the timescales, Charges or Surcharges for the rectification of such faults and/or to cover any reasonable costs amending such Posting(s) has been agreed in writing (including, electronically or by fax) with your Operational Contact.

The following table sets out the actions we may take if you do not comply with your Contract including this User Guide. It also sets out the procedures you are required to follow. If you have correctly used a UCID and the non-compliance relates only to that UCID Posting, the actions will only be taken in respect of that UCID Posting. If the non-compliance relates to a Consolidated Posting, i.e. to any part of a Posting which is not a UCID Posting, our actions may be taken in respect of the whole of that Consolidated Posting. In this table we use the term "relevant segment" to mean that part of the Posting or Daily Posting, as the case may be, i.e. UCID Posting or Consolidated Posting to which the non-compliance relates.

If you do not use UCIDs, Mailing Items of the same format and Service will be treated as a Consolidated Posting, and the term 'relevant segment' in this section will mean all Containers relating to the same format and Service in the Daily Posting which do not bear a UCID. In this section, Reference to Containers shall apply to bundles presented as per the Unbagged specification [Appendix D](#).

Where we are entitled to reject any Containers of non-compliant Postings or UCID Postings at an Inward Mail Centre, we may levy a charge to cover the reasonable costs of handling and you are responsible for the collection of the affected Containers. In the event that the Containers have not been collected by you during the following Working Day after notification, we may levy a charge to cover the reasonable costs of storage. In the event that the Containers have not been collected by you within 5 Working Days of notification, we may dispose of the Containers and their contents as we see fit and levy a charge to cover the reasonable costs of disposal.

ROYAL MAIL WHOLESALE

15.1 Pre-notification and Pre -Advice	
Issues	Corrective Action
<p>15.1.1</p> <p>No receipt of Pre-notification</p>	<p>If the details of the Posting(s) have not been pre-notified due to a failure on your part by 10:00 on the Working Day prior to Handover Day we may refuse handover of the Posting(s). You must contact DSACC to agree on arrangements for the handover of the Posting(s).</p> <p>If we have not received pre-notification of the details of the Posting(s) due to a failure on our part we shall accept handover of the Posting(s) affected by the failure.</p>
<p>15.1.2</p> <p>Inaccurate Pre-notification</p>	<p>If the actual number of Mailing Items handed over at an individual Inward Mail Centre is more than the volume forecasted and the variation from the Pre-notification is more than the Tolerance, we may:</p> <ul style="list-style-type: none"> • refuse the handover of; or • accept the handover of any Mailing Items which exceed the Tolerance of the relevant format. <p>Any Containers of the relevant format we accept will be excluded from the Service Standard measure and will be processed as if they had been received on the following Working Day.</p> <p>If the actual volume of Mailing Items which you hand over at an individual Inward Mail Centre is less than the volume forecasted in your Pre-notification by more than the Tolerance, we may levy a charge. This charge is for "Over Forecasting".</p> <p>The charge applied can be found under "Other Charges" in the pricing tables at www.royalmailwholesale.com , as amended from time to time in line with the Contract.</p>
<p>15.1.3</p> <p>Inaccurate 06:30 Posting Docket and Manifests</p>	<p>On a Handover Day, if you become aware of a variance between the volume of Mailing Items for handover and your Posting Docket and Manifests due to events outside your control you must inform DSACC immediately via DocketHub of any misrouted Containers and of any Exceptions (including additional or fewer Containers) by no later than the following times that Handover Day:</p> <ul style="list-style-type: none"> • 06:30am for Inward Mail Centres with a handover time up and including 09.30am; • 08.30am for Inward Mail Centres with a handover time of up to and including 11.00am; • 10:00am for all other Inward Mail Centres. <p>All agreed Exceptions shall be recorded by you within DocketHub as per the timescales above.</p> <p>Where the actual variance is in excess of the number of Containers declared and we are able to agree to the handover of the Exceptions on that Handover Day, any such Containers will be excluded from the Service Standard measure and will be processed as if they had been received on the following Working Day. We may require all additional Containers reported to DSACC via Exception reports to be handed over separately at the handover point of the relevant Inward Mail Centre.</p>

ROYAL MAIL WHOLESALE

<p>15.1.4 No Vehicle Declaration provided</p>	<p>Each Working day, you shall accurately declare to us via DocketHub the number of vehicles due to arrive at each Inward Mail Centre for each Access Slot (Vehicle Declaration). For Access Slots prior to 09:00, you must upload your Vehicle Declaration no later than half an hour before your due Access Slot, and for Access Slots from 09:00 onwards, you must upload your Vehicle Declaration by 08:30. If you fail to provide a Vehicle Declaration at each Inward Mail Centre for each Access Slot by the upload time required we may:</p> <ul style="list-style-type: none"> • Agree to accept the Mailing Items if it is operationally practical for us to do so at each Inward Mail Centre. In such circumstances the accurate number of Containers must have been provided on both the Vehicle Manifest and the Summary Vehicle Manifest. In accepting the Mailing Items we may reasonably raise an administration charge for managing any additional administration work required to accept and confirm the vehicles at handover; <p>Or</p> <p>If it is not operationally practical for us to do so, we may refuse the Mailing Items until an accurate Vehicle Declaration is provided.</p>
<p>15.2 Arrival</p>	
<p>15.2.1 No Access Slot has been booked at DSACC for an Inward Mail Centre</p>	<p>If you arrive at an Inward Mail Centre without booking an Access Slot then we will refuse handover of the Posting(s). If you fail to book an Access Slot and you still wish to hand over the Posting(s), you must contact DSACC to agree on arrangements for the handover of the Posting(s).</p>
<p>15.2.2 Non-arrival of Posting(s)</p>	<p>Where you have provided us with a pre-notification and you do not inform us on the day before the Handover Day that you wish to cancel a Posting, we may levy a charge. This charge is called "Vehicle No Show". The Posting(s) will be considered void and will be logged by DSACC.</p> <p>If in the unlikely circumstance that you have sent us a Posting Docket and Manifests but you are unable to handover the Posting(s) at any Inward Mail Centre, you must contact DSACC as soon as possible. We will void the Posting(s) and it will be logged by DSACC as a "Vehicle No Show". We may levy a charge for an expected Posting that does not arrive.</p> <p>The charge applied can be found under "Other Charges" in the pricing tables on the pricing page at www.royalmailwholesale.com as amended from time to time in line with the Contract.</p>
<p>15.2.3 Non adherence to site security</p>	<p>You must comply with the notified site-specific security procedures (including contingency arrangements). Where these are not complied with, we will refuse the driver access or ask him or her to leave. Wherever possible we will provide reasonable notification of changes to security procedures.</p>
<p>15.2.4 Arrival time outside of Access Window</p>	<p>If you are unable to arrive within the agreed Access Window, we will refuse handover of the Posting.</p>

ROYAL MAIL WHOLESAL

<p>15.2.5 Arrivals outside of the Access Slots</p>	<p>If you are unable to arrive during the agreed Access Slot you must inform DSACC at the earliest opportunity to request an alternative arrival time and agree on arrangements for the handover of the Posting(s).</p> <p>If you arrive before the Access Slot (but within the Access Window) we may allow hand over of the Posting(s) if operationally feasible for us. If we are unable to accept handover the driver will be asked to wait or leave the premises until your allocated Access Slot or an earlier Access Slot becomes available.</p> <p>If you arrive after the Access Slot (but within the Access Window) we will allow handover the Posting(s) if operationally feasible for us, subject to you gaining prior approval from DSACC. If the Posting(s) can only be accepted after the Access Slot (but within the Access Window), your nominated contact may be notified by DSACC that the Posting(s) will be removed from the Service Standard measure and processed as if it had been received on the following Working Day.</p> <p>If you arrive during the agreed Access Slot but you are unable to handover the Posting(s) due to a reason attributable to us, we will allow handover of the Posting(s) in the next available Access Slot but the Posting(s) will be treated (including for the purposes of the Service Standard) as having been handed over during the earlier Access Slot</p>
<p>15.2.6 No notification provided for multiple vehicles in a pre-booked Access Slot</p>	<p>If you fail to provide the necessary notification of multiple vehicles and still wish to hand over the Posting(s), you must contact DSACC to agree arrangements for the handover of the Posting(s).</p> <p>If you have not notified DSACC that you will be bringing in multiple vehicles within their pre-booked Access Slot then we may refuse handover of the Posting(s).</p>
<p>15.2.7 Inaccurate Vehicle Declaration</p>	<p>If you fail to provide an accurate Vehicle Declaration at each Inward Mail Centre for each Access Slot by the upload time required we may:</p> <ul style="list-style-type: none"> • Agree to accept the Mailing Items, if it is operationally practical for us to do so, at each Inward Mail Centre. In such circumstances the accurate number of Containers must have been provided on both the Vehicle Manifest and the Summary Vehicle Manifest. In accepting the Mailing Items we may reasonably raise an administration charge for managing any additional administration work required to adjust and confirm the vehicles hand over; <p>Or</p> <ul style="list-style-type: none"> • If it is not operationally practical for us to do so, we may refuse the Mailing Items until an accurate Vehicle Declaration is provided.
<p>15.3 Documentation</p>	
<p>15.3.1 No Posting Docket(s) or Manifest(s) received at DSACC</p>	<p>If the relevant Posting Docket(s) and Manifest(s) have not been received by DSACC by 06:30am on the Handover Day we will refuse handover of the Posting. You must contact DSACC at the earliest opportunity to agree possible arrangements for the handover of the Posting(s).</p>

ROYAL MAIL WHOLESALE

<p>15.3.2 Hard copy Manifest(s) including Summary Vehicle Manifest, if applicable) not received at handover at Inward Mail Centres.</p>	<p>We may, subject to DSACC's agreement, allow hand over of a Posting in respect of which a hard copy Manifest(s) or Summary Manifest is not provided to us by a driver, subject to the receipt of the Posting Docket and electronic Manifest by 06:30am on the Handover Day. However, the Posting will not be processed until such time as the hard copy Manifest(s) relating to that Posting(s) is received at the Inward Mail Centre and the Posting(s) shall be deemed to have been received on the following Working Day.</p> <p>If the Manifest(s) is not received within 24 hours, we may reject the Posting(s). In this case, the Posting Docket(s) will be adjusted and the Mailing Items must be included on a subsequent and relevant Posting Docket(s).</p> <p>We may refuse handover of any subsequent Postings at the Inward Mail Centre(s) affected until the relevant Manifest(s) has been received.</p>
<p>15.3.3 The number, weight or format of Mailing Items declared on the Manifest(s) does not tally with the number, weight or format of Mailing Items handed over</p>	<p>If we detect any variance detected through sampling between the declared numbers, weight or format of Mailing Items on the Manifest(s) from those actually handed over at the Inward Mail Centre, we will revert your Mailing Items to the correct Postage by be used to amending the Posting Docket(s) and Manifest(s).</p> <p>Where we have statistically significant evidence that the number of Mailing Items declared on the Manifest(s) represents an error across a Posting or relevant segment of a Posting, then we may amend the Posting Docket based upon the statistically significant evidence.</p> <p>We may hold the Posting(s) or the relevant segment of the Posting(s), until such time as the changes are agreed.</p> <p>If the changes are not agreed within 24 hours of handover we may reject the Posting(s) or the relevant segment of the Posting(s).</p> <p>Exception to this remedy for weight variances on Mixed Weight Postings: Due to the Mixed Weight system constraints, if an Under Volume Container is sampled on a Mixed Weight Posting, and the actual weight of the Mailing Items handed over differs from the declared value, we will invoice the declared value only. Under Volume</p>
<p>15.4 Indicium</p>	
<p>15.4.1 Mailing Items do not bear an approved Indicium or the Royal Mail Access Indicator.</p>	<p>If a Posting(s) or a relevant segment of a Posting(s) is found to contain Mailing Items that do not bear an approved clear and legible Indicium or carry the Indicium of another Customer we may reject the Posting(s) or relevant segment of the Posting(s).</p>
<p>15.4.2</p>	<p>If a Posting(s) or relevant segment of a Posting(s) is found prior to acceptance to contain Mailing Items that do not bear a UK return address, we may reject the Posting or relevant segment of the Posting.</p>

ROYAL MAIL WHOLESALE

<p>Mailing Items do not bear a UK return address</p>	<p>Where a Posting(s) or relevant segment of a Posting(s) is found after acceptance, to contain Mailing Items that do not bear a UK return address, if any such Mailing Items were to be returned to us as undeliverable or not wanted, we are not obligated to return such Mailing Items to you. We may dispose of those Mailing Items that have been returned to us and levy a charge to cover the reasonable costs of handling.</p>
<p>15.5 Addressing Standards</p>	
<p>15.5.1 Mailing Items that fail to meet the Addressing Standards as specified in this User Guide</p>	<p>If a Posting(s) or relevant segment of the Posting(s) fails to meet the Addressing Standards that Posting(s) or relevant segment of the Posting(s).</p> <p>Or, provided you have handed over the Posting at the correct Inward Mail Centre and if we agree it is operationally feasible to process, you will be charged the prevailing Access Zone C rate relevant to the Mailing Items unless the Mailing Items are for delivery to the London Zone in which case you will be charged the prevailing Zone D rate.</p>
<p>15.6 Mail Presentation</p>	
<p>15.6.1 Mailing Items are not sorted in line with the Sortation Specification (e.g. Parcels are declared as 1400 when they are sorted to 70), or are sorted not using either a mandatory Access Selection File Version or Access Selection File Release.</p>	<p>If a Posting(s) or a relevant segment of a Posting(s) is found to contain Mailing Items that are not sorted in line with the correct sortation specification, we may reject that Posting(s) or relevant segment of the Posting(s). Either:</p> <p>you must collect the Posting(s) or relevant segment of the Posting(s);</p> <p>Or If the sortation service declared is incorrect to the actual sortation Service used, and we agree that it is reasonably practicable for us to do so, we will process the Posting(s) or relevant segment of the Posting(s). In this case we will revert the Mailing Items to the correct Postage by amending the Posting Docket to reflect that all Mailing Items will be charged at the applicable Access service level to which they have been sorted.</p> <p>Where we have statistically significant evidence that the error declared on the Manifest represents an error across all relevant segments, then we may amend the Posting(s) based upon the statistically significant evidence;</p> <p>Or If a mandatory Access Selection File Version has not been used, and we agree that it is reasonably practicable for us to do so, we will process the Posting(s) or relevant segment of the Posting(s). In this case we will revert the Mailing Items to the correct Postage by amending the Posting Docket to reflect that the affected Posting(s) will be charged at the prevailing Access Zone C rate unless the Posting(s) are for delivery to the London Zone in which case you will be charged the prevailing Zone D rate. Where we have statistically significant evidence that the error declared on the Manifest represents an error across all relevant segments, then we may amend the Posting(s) based upon the statistically significant evidence;</p>

ROYAL MAIL WHOLESALE

	<p>Or</p> <p>If a mandatory Access Selection File Version Release has not been used, and we agree that it is reasonably practicable for us to do so, we will process the Posting(s) or relevant segment of the Posting(s). Where we have evidence that the Zonal Mailing Items handed over have been incorrectly declared to the new Access Selection File Version Release, we will revert the Mailing Items to the correct Postage by amending the Posting Docket to reflect the correct Zone for those Mailing Items identified and the relevant Zonal charges will apply.</p> <p>Where we have evidence that Zonal Mailing Items handed over have been incorrectly declared to the new Access Selection File Version Release after 14 or more days after mandatory Access Selection File Version Release date has come into effect, we may reject the Mailing Items.</p> <p>Where we have statistically significant evidence that the error declared on the Manifest represents an error across all relevant segments, then we may revert the Mailing Items to the correct Postage by amending the Posting(s) based upon the statistically significant evidence.</p>
<p>15.6.2</p> <p>Containers of Mailing Items are handed over to the wrong Inward Mail Centre (misrouted Container)</p>	<p>If you hand over Containers of Mailing Items at the wrong Inward Mail Centre (i.e. containing Mailing Items for delivery to Postcodes which are not served by that particular Inward Mail Centre), we may reject those Containers and either:</p> <ul style="list-style-type: none"> • you must collect the Containers wrongly handed over at the relevant Inward Mail Centre. We may levy a charge to cover the reasonable costs of handling these Containers; <p>Or</p> <ul style="list-style-type: none"> • if we agree that it is reasonably practicable, we will process the Containers. In this case we will amend the Posting Docket to reflect that the relevant Mailing Items will be charged at the Missort Processed item rate displayed on our Website www.royalmailwholesale.com/prices.
<p>15.6.3</p> <p>Mis-sorted Mailing Items are found during the processing of the Posting(s)</p>	<p>If we find mis-sorted Mailing Items during the processing of the Posting(s) (after hand over or acceptance), we may reject those Mailing Items and either:</p> <ul style="list-style-type: none"> • you must collect the mis-sorted Mailing Items from the relevant Inward Mail Centre and we may levy a charge, the "Missorts Returns Charge". The Missort Return Charge" includes a per Mailing Item price + a collection charge per Inward Mail Centre collection. Where such charges are levied, we shall refund you for those mis-sorted Mailing Items at the prevailing Access refund rate. The Charges and the national average Access refund rate will be set each time we adjust our tariff. Mis-sorted Mailing Item Returns Charges and the national average Access refund rate are displayed on our Website www.royalmailwholesale.com/prices; <p>Or</p> <ul style="list-style-type: none"> • if we agree that it is reasonably practicable we will process the Mailing Items. In this case we will amend the Posting Docket to reflect that the relevant Mailing Items will be charged at the "Mis sort Processed" rate and you will receive a refund for the same items at the agreed Access refund rate. Mis-sorted Mailing Item Charges are displayed on our Website www.royalmailwholesale.com/prices.

ROYAL MAIL WHOLESALE

<p>15.6.4</p> <p>Containers of Mailing Items are presented at the Inward Mail Centre without labels or with missing/incorrect information on the labels or have the wrong colour labels relevant to the Service</p>	<p>In the event that you fail to label the Container(s) correctly and as a result we are unable to verify whether the Container has been correctly declared on the Posting Docket, we may reject the Container(s).</p>
<p>15.6.5</p> <p>You fail to maximise the Container fill for each Selection in a Posting(s) within the maximum weight limit</p>	<p>You must where possible maximise the Container fill for each Selection within the Posting(s) up to the applicable Container's maximum allowable weight limit, subject to meeting the requirement for accurate Container contents.</p> <p>If we find that the number of Containers is excessive because Container fill has not been maximized in accordance with section 5, we may levy a Surcharge for the processing of the Containers.</p>
<p>15.6.6</p> <p>Containers contain mixed formats and/or Mailing Items are not presented in Containers as specified in section 5 of this User Guide</p>	<p>If you handover Containers which contain mixed formats or are not presented as specified in section 6 of this User Guide then we may reject the Posting or relevant segment of the Posting. The Posting(s) or relevant segment of the Posting(s) will be held and we will contact you:</p> <p>Or</p> <ul style="list-style-type: none"> • if we agree that it is reasonably practicable for us to do so, we will correctly segregate the Posting(s) or relevant segment of the Posting(s) provided you agree to pay a Surcharge; <p>Or</p> <ul style="list-style-type: none"> • if we agree that it is reasonably practical for us to do so we will process the Mailing Items and all Mailing Items will be charged at the relevant Charges <p>Where we have statistically significant evidence that the error represents an error in other Containers of the same relevant segment at other Inward Mail Centres, then we may take the corrective action to the relevant segment and amend the Daily Posting based upon the statistically significant evidence.</p>
<p>15.6.7</p> <p>Mailing Items are not correctly faced and/or bundled in line with the sortation and presentation specification for the Service</p>	<p>If you handover Mailing Items that have not been correctly faced and/or bundled in relation to the Service and Container to which they have been declared, we may reject the Posting(s) or relevant segment of the Posting(s). The Posting(s) or relevant segment of the Posting(s) will be held and we will contact you. Either:</p> <ul style="list-style-type: none"> • you must collect the incorrectly faced and/or bundled Mailing Items; <p>Or</p> <ul style="list-style-type: none"> • if we agree that it is reasonably practicable we will process the Posting(s) or relevant segment of the Posting(s) provided you agree to pay a Surcharge.

ROYAL MAIL WHOLESALE

<p>and/or Container in which they are presented</p>	
<p>15.6.8 Zonal Mailing Items do not bear a Zonal Indicator or bear an incorrect Zonal Indicator</p>	<p>If you handover Mailing Items under a Zonal Price Plan and either do not have any Zonal Indicator or do not bear the correct Zonal Indicator on the face of each item, we may reject the Posting(s) or relevant segment of the Posting(s). The Posting(s), or relevant segment of the Posting(s), will be held and we will contact you. Either:</p> <ul style="list-style-type: none"> • on prior arrangement with us, you may upload and pay for those Mailing Items as Zone C, except for those Mailing Items for destination to the London zone in which case you will upload and pay for all such Mailing Items as Zone D; <p>Or</p> <ul style="list-style-type: none"> • if we agree that it is reasonably practical we will process the Posting(s) or relevant segment of the Posting(s) provided you agree to pay for all Mailing Items at Zone C unless the Mailing Items are for the London Zone in which case they will be charged at Zone D <p>Where we have statistically significant evidence that the error represents an error in other Containers of the same relevant segment at other Inward Mail Centres, then we may take the corrective action to the relevant segment and amend the Daily Posting based upon the statistically significant evidence.</p>
<p>15.6.9 Mailing Items are handed over in poor condition</p>	<p>We will visually check the condition of the Containers upon hand over. We may refuse the handover of any Posting(s) or relevant segment of the Posting(s) if the Containers are obviously damaged or in a generally poor condition. We may reject any Mailing Items that our staff subsequently discover (prior to acceptance) to be damaged or in generally poor condition.</p> <p>We will contact your Operational Contact and you must collect the damaged Mailing Items or Containers. Where we have statistically significant evidence that the error represents an error in other Containers of the same relevant segment at other Inward Mail Centres, then we may take the corrective action to the relevant segment and amend the Daily Posting based upon the statistically significant evidence.</p>
<p>15.6.10 Mailing items handed over are stuck together.</p>	<p>If Mailing Items within a Posting(s) or relevant segment of the Posting(s) are stuck together then we may reject the Posting(s) or relevant segment of the Posting(s). The Posting(s) or relevant segment of the Posting(s) will be held and we will contact you. Where we agree that it is practicable to separate the Mailing Items, and you agree to pay a Surcharge, we will process the Mailing Items.</p> <p>If, in our opinion, the Mailing Items cannot be separated without damaging the Mailing Items then you must collect the Mailing Items and we may levy a charge to cover the reasonable costs of handling.</p> <p>Where we have statistically significant evidence that the error represents an error in other Containers of the same relevant segment at other Inward Mail Centres, then we may take the corrective action to the relevant segment and amend the Daily Posting based upon the statistically significant evidence.</p>

ROYAL MAIL WHOLESALE

<p>15.6.11 UCID Postings or Consolidated Postings are not clearly identified and/or not segregated as required</p>	<p>If you fail to identify clearly on hand over of the Posting(s) or relevant segment of a Posting, Containers within the Posting(s) or relevant segment of a Posting which relate to a UCID Posting and/or you fail to segregate any such Postings as and when required by us, we will not be able to treat such Containers as separate Postings for Revenue Protection purposes. In such case we may reject the relevant Mailing Items and we will have to assume that any errors found apply across all such Mailing Items which have not been clearly identified as UCID Postings or segregated when requested (as applicable). The relevant Mailing Items will be held and we will contact you. Either:</p> <ul style="list-style-type: none"> • you must collect the Mailing Items that have not been clearly identified or segregated and we may levy a charge to cover the reasonable costs of handling; <p>Or</p> <ul style="list-style-type: none"> • we may assume that any errors identified in such Containers occur across all those Containers that are not clearly identified and will therefore apply the provisions of this Section 15 and Schedule 2 of the Contract to all such Mailing Items.
<p>15.6.12 Oversize Mailing Items</p>	<p>We will reject Mailing Items that exceed the maximum size dimensions as laid down in section 5 of the User Guide. If you wish to post Mailing items that exceed these dimensions you could use an alternative Royal Mail service, such as our Standard Parcels service for non-urgent and non-time-critical delivery, or Parcelforce Worldwide has range of guaranteed parcel services.</p>
<p>15.6.13 Discrete Customer Postings are not identifiable due to missing or inaccurate York Card(s).</p>	<p>If one York at an Inward Mail Centre has a York card missing or an inaccurate York card, we may refuse handover of the York and require you to collect the York, or we may accept the York subject to the Discrete Customer Postings within the York agreeing with the Manifest. If more than one York at an Inward Mail Centre has a York card missing or an inaccurate York card, we will refuse handover of the Yorks. In such cases, you must collect the Yorks whose contents have not been clearly identified and we may levy a charge to cover the reasonable costs of handling.</p>
<p>15.6.14 Discrete Customer Postings are not reasonably separated within a York by cardboard or other effective means (e.g. Containers from a Zonal Option are mixed with Containers from a National Option; Containers from a</p>	<p>Where you are handing over Discrete Customer Posting(s) under more than one Contract, if you do not maintain segregation of the Discrete Customer Posting(s) then we may reject them. You must collect the Discrete Customer Posting(s) and we may levy a charge to cover the reasonable costs of handling.</p> <p>This remedial action is not applicable to Customers who have entered into the supplementary agreement for 'Segregation By Format' since the terms of that agreement allow Discrete Customer Postings to share a York container with other Discrete Customer Postings provided that the York container contains an accurate York card and an accurate York Manifest has been provided in accordance with the Segregation By Format Schedule.</p>

ROYAL MAIL WHOLESALE

<p>Mixed Weight Posting are mixed with Containers from a non Mixed Weight Posting.)</p>	
<p>15.6.15 Mailing Items are handed over that are not eligible for Access (e.g. International and BFPO addresses)</p>	<p>If we find ineligible Mailing Items at the point of handover or during the processing of the Posting(s) (after handover or acceptance), we may refuse handover or to reject the Mailing Items, as applicable. You must collect the ineligible Mailing Items from the relevant Inward Mail Centre and we may levy a charge to cover the reasonable costs of handling. We will:</p> <ul style="list-style-type: none"> • refund the Postage raised against the equivalent volume of ineligible Mailing Items identified. The Access refund rate will be equivalent to the unit price of the Access overall average unit price for each discrete format of the overall Access postings based on the previous April to December period plus RPI (national average Access refund rate). The national average Access refund rate is displayed on our Website www.royalmailwholesale.com • charge each ineligible Mailing Items found, extracted and returned, at a per item price + a collection charge per Inward Mail Centre collection. Ineligible Mailing Item charges are displayed on our Website www.royalmailwholesale.com <p>The national average Access refund rates and the Ineligible Mailing Item Charges will be set each time we adjust our tariff. Mailing Item Charges are displayed on our Website www.royalmailwholesale.com/prices</p>
<p>15.6.16 Mailing Items are not handed over in the correct Container required for the Service or their format.</p>	<p>If you hand over Mailing Items in a Container not permitted for the specified service or format or not in adherence to the relevant Container requirements including labelling and sealing as set out in this User Guide:</p> <ul style="list-style-type: none"> • we may reject the Posting(s) or relevant segment of the Posting(s) and we may levy a charge to cover the reasonable costs of handling; <p>Or</p> <ul style="list-style-type: none"> • If we agree that it is reasonably practicable to process the Posting(s) or relevant segment of the Posting(s) we shall amend the Posting Docket accordingly and we may levy a Surcharge to cover the reasonable costs of any additional handling that may be incurred in processing the Mailing Items and/or any administration costs. <p>Where we have statistically significant evidence that the error represents an error in other Containers of the same relevant segment at other Inward Mail Centres, then we may take the corrective action to the relevant segment and amend the Daily Posting based upon the statistically significant evidence.</p>
<p>15.6.17 Parcels for Channel Islands</p>	<p>If you hand over Mailing Items destined for the Channel Islands not in bags as per section 5.3 of this User Guide we will reject the Posting(s) at the relevant Inward Mail Centre and require you to return to collect the Posting(s).</p>

ROYAL MAIL WHOLESALE

<p>are not presented in bags</p>	<p>A Parcel that cannot fit into our standard sized mail bag due to the Parcels physical dimensions must be presented and labelled as an individual Container in order for it to be accepted.</p>
<p>15.6.18 Containers are not presented in Yorks or Tray Dollys as required for Acceptance By Vehicle.</p>	<p>If Containers are not presented in Yorks or Tray Dollys in any vehicle at an Inward Mail Centre, we shall refuse to accept the vehicle.</p>
<p>15.7 Health and Safety</p>	
<p>15.7.1 The weight of any of our approved Containers exceeds the maximum weight specified for it</p>	<p>If we find that the weight of any Container handed over by you exceeds the maximum weight specified for it we may reject the relevant Container which will be held and we will contact you:</p> <ul style="list-style-type: none"> • you shall collect the overweight Container; <p>Or</p> <ul style="list-style-type: none"> • if we agree that it is reasonably practical to do so, we will levy a Surcharge for breaking down the Container(s) into compliant Container fills, which meet our Health & Safety standards.
<p>15.7.2 The driver does not adhere to site Health and Safety requirements</p>	<p>Any driver not conforming to all health and safety requirements will be refused access to the Inward Mail Centre or if already on the premises may be asked to leave. This may result in the Posting(s) not being accepted. Any vehicle reasonably deemed not road-worthy by us will not be allowed access to our Inward Mail Centre. Any abusive or threatening behaviour (physical or verbal) towards any of our employees will not be tolerated and access will be refused.</p>

Appendix A: Addressing Mailing Items

You must make all reasonable attempts to ensure all Mailing Items include a full and accurate address and corresponding Postcode. You must ensure that at least 90% of Mailing Items carry a full and accurate address and corresponding Postcode, which has been validated against the our Postcode Address File (PAF®)

Cleaning address data should not be a one-off activity, but an on-going process.

The best way for you to ensure you maintain the accuracy of your address files is for it to link your databases to PAF® by using one of the large number of available products and services based on PAF® which are available.

PAF® contains over 29 million UK addresses, including 1.4 million business names and 1.8 million UK Postcodes, which we constantly updates to maintain its accuracy.

Where to go for more information

For more information or to order Managing Address Data products:

Call Royal Mail on 0845 606 6854

Visit the Royal Mail Website at www.royalmail.com/amu

Order products via our Website shop at www.royalmail.com/shop

Order products online from: address.management@royalmail.com

The Elements of an Address & Address Structure

To meet the required address standards you must ensure that each address includes at least one premises element, one thoroughfare element, one locality element and the Postcode as a minimum. Other elements may be included. If there is no thoroughfare element contained in PAF® this need not be included.

Each element is described here.

PAF Format		Element
Organisation	Royal Mail	Premises
Sub Building		
Building Name	Wheatstone House	
Building Number		
Dependent Thoroughfare		Thoroughfare
Thoroughfare	Wheatstone Road	
Double Dependent Locality		Locality
Dependant Locality	Dorcan	
Post Town	SWINDON	
County		Not required
Postcode	SN3 5XX	Postcode

1. Premises Elements

All Mailing Items must include at least one of these four elements, so that a single Delivery Point is defined. You do not have to include all the premises elements (unless the premises elements used do not sufficiently describe an address), even if they are included in PAF®, but building numbers must be applied on the same line as the Dependant Thoroughfare or Thoroughfare information.

2. Thoroughfare Elements

PAF® will give one of three possible combinations:

- No thoroughfare: no need to include anything in this part of the address.
- A thoroughfare but not a dependent thoroughfare: include the thoroughfare.
- Both a dependent thoroughfare and a thoroughfare: include the former. If space allows you can also include the thoroughfare, though it's not compulsory.

3. Locality Elements

You must include at least one locality element, it does not have to include them all, even if they are included in PAF®. The initial letter(s) of the post town must always be in capital letters, for example Milton Keynes. Alternatively the whole of the post town may be in capital letters, for example: BIRMINGHAM on a line on its own, as indeed can the whole of the Delivery Address.

4. Postcode

The address must contain the full and accurate Postcode. The Postcode must be able to generate an address from PAF® which can be matched to the minimum requirements above (at least one premise element, one thoroughfare element and one locality element). The Postcode must always appear in capital letters and, unless with the exception of examples 5a), 5b) and 5c) below, on its own as the last line of the address.

Do not include any punctuation or underline it. Please put one or two character spaces between the two parts of the Postcode. The first part (i.e. SN3) is the outward code, the second (i.e. 5XX) in the inward code.

5. Address Structure

Each address element must be on a separate line with the Postcode included as the last line of the address.

Royal Mail
Wheatstone House
Wheatstone Road
Dorcan
SWINDON
SN3 5XX

a) where the address complies with PAF® and there is no other text or information on the face of the Mailing Item that could be construed as an address, then the following exceptions apply:

The Postcode may be preceded by a county on the last line of the address, provided that the space between the county and the Postcode is one or two characters.

Royal Mail
Wheatstone House
Wheatstone Road
Dorcan
SWINDON
Wiltshire SN3 5XX

b) the post town may be followed by a county on the penultimate line of the address, provided that the space between the post town and county is one or two characters and that the Postcode is on the last line of the address.

Royal Mail
Wheatstone House
Wheatstone Road
Dorcan
SWINDON Wiltshire
SN3 5XX

c) the post town and Postcode may be jointly on the last line of the address, provided that the post town precedes the Postcode and the space between the two elements is one or two characters.

Royal Mail
Wheatstone House
Wheatstone Road
Dorcan
SWINDON SN3 5XX

The County, although not required, may be included as the penultimate line of the address, with the exception of example b) illustrated above.

6. Zonal Addressing

Zonal Postings must include the Zonal Indicator. There are two options relating to the position of the Zonal Indicator (please see figure 26), positioned within the top right hand area of the address window immediately following the SSC (zone A, B, C or D) e.g. 53200 A, or preceded by the word 'Zone' and be in a minimum font size of 10 point (e.g. Zone A).

Figure 26: Zonal indicator positioning

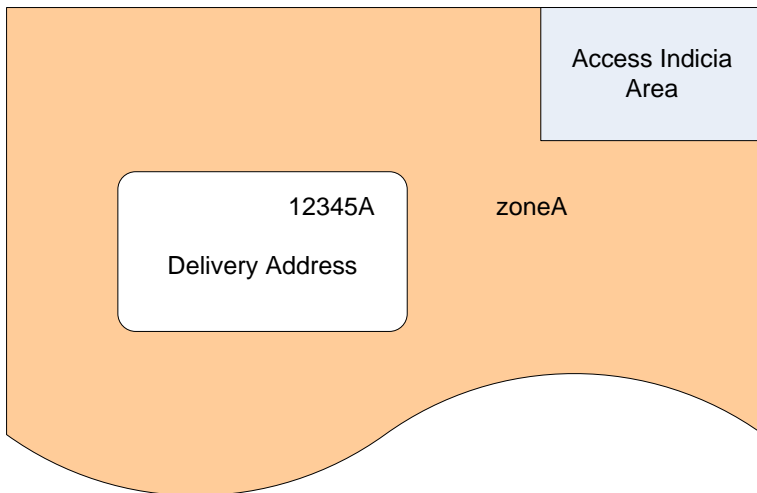

The simplest way to ensure an address is correct is to check that the minimum address elements in the appropriate PAF® records are present.

Appendix B: Access Selection Files

Obtaining a copy of the Access Selection Files

Selections for our Services are derived from our Access Selection Files which are available free of charge in a number of computer formats from the Technical Helpline on 0207 371 3727. It can also be downloaded from our Website www.royalmailwholesale.com.

Using the Access Selection Files

The Access Selection Files provide the key data to enable you to sort your Mailing Items into the sortation levels. The Access Selection Files contain data only and not software. You will need to write some software to sort your Mailing Items, or purchase a tailor-made product from a software supplier. A list of suppliers can be found on our Website www.royalmailwholesale.com

Mailing Items are split into different sortation levels: 70 and 1400

What are 1400 Selections?

1400 requires Mailing Items to be sorted into Selections based on Postcode Districts. The Access Selection Files contain around 1525 of these Selections.

What are 70 Selections?

70 require Mailing Items to be sorted into Selections based on Postcode Areas. The Access Selection Files contain around 86 of these Selections.

Standard Selection Codes (SSC)

Each Selection in the Access Selection Files is allocated a unique numeric code – the Standard Selection Code (SSC). The main purpose of the SSC is to identify service level Selection for computer sorting and for Container label identification. A 1400 Selection Code has a five-digit SSC. A70 Selection Code has a three-digit SSC (this may be expressed as a 5 digit SSC with two additional '00')

Sorting to 1400

Mailing Items need to be sorted to the 5 digit Selections contained in the Access Selection Files.

Sorting to 70

Mailing Items need to be sorted to the 3 digit Selections contained in the Access Selection Files.

Updating the Access Selection Files

The Access Selection Files are updated periodically to reflect any Postcode changes. By downloading the Access Selection Files from our Website you will be automatically added to a circulation list informing you of changes. You will be advised of changes and the arrangements for implementing updates. It is your responsibility to ensure that you implement these changes and that the current version of the Access Selection Files is used.

Appendix C: Unwrapped Specification

1. Introduction

It is possible for us sometimes to accept Mailing Items without wrapping or envelopes. This option is only available for 1400 Selections and not for any other Service. Typically this method of presentation is suited to magazines or catalogues.

2. Presentation requirements

The conditions which apply to acceptance of Mailing Items, presented in this way are stated here.

Your Access Account Director will ensure that you are aware of the additional presentation requirements.

All unwrapped Mailing Items must be included in the 7 Working Day rolling forecast and Pre-notification forecast and in the 06:30am docket upload as per [section 11](#)

- you must apply the correct CFL to each Container
- Parcels can be bundled or loose when presented in bags
- Mailing Items must be loose when presented in ALPS
- if Mailing Items are presented in bundles without bags the bundles must be crossed strapped or alternatively wrapped in polywrap of 30 microns and the requirements of [Appendix D](#) – Strapped Bundle/Unbagged must be met.
- for bundles held together by polywrap the bundle CFL must comprise of a white adhesive label of comparable size to the normal bag label (120mm x 50mm) and be applied to the outside of the polywrap. The CFL must be applied in such a position that it obscures the Delivery Address of the Mailing Item beneath the wrapping to avoid the bundle being perceived as a single Mailing Item. We will not supply this type of label.
- the minimum number of Mailing Items required per Container is as detailed in [section 6](#)
- no individual Mailing Item may be more than 324mm x 458mm or less than 125mm x 176mm in size
- Mailing Items will be priced according to their format as detailed in [section 5](#)
- each Mailing Item is to be pre-addressed on the cover, in a position to be agreed with your Access Account Director
- each Mailing Item must have an approved Indicum as a method of postage payment. (see [section 3](#) for more detail)
- the address area on each Mailing Item should, only include the Delivery Address and may also include the return address, be white, buff or of pale colour and at least 76mm x 127mm
- all pages of each Mailing Items within each Posting must be of the same size and fixed together by staples or other means; loose inserts are not allowed. The exception to this is the fact that the facing cover of the Mailing Item may be a smaller size – e.g. either half the length or the width of the rest of the item. This is providing that;
 - it is securely affixed to spine of the item
 - the address and Indicum layout meets specification and are both clearly visible
 - where CFL information has been printed on, this meets the current requirements in terms of layout and design
- we will destroy any Mailing Items that are undeliverable through lack of address particulars or because the address covers have become torn in transit.
- we cannot give any assurance on redirected unwrapped Mailing Items
- we cannot accept responsibility for damage in transit for these unwrapped postings and any recipient complaints will be referred to the sender.

Appendix D: Strapped Bundle/Un-bagged Specification

1. Presentation

You must post at least 4,000 Mailing Items to present Mailing Items as strapped bundled/unbagged. Your Access Account Director will make sure you are aware of the presentation requirements.

All strapped bundled Mailing Items must be included in the 7 Working Day rolling forecast and Pre-notifications forecast and in the 06:30am docket upload as per [section 11](#)

2. Presentational Requirements

The dimensions of the Mailing Item must fall between 125mm x 176mm and 324mm x 458mm

Mailing Items will be priced according to their format as detailed in [section 5](#).

The number of Mailing Items within each bundle must be maximised and comply with maximum bundle weight limits. An Under Volume bundle is a bundle that does not contain the minimum number of Mailing Items in each weight step as defined in [section 6](#). Under Volume bundles will be charged in accordance with [section 6](#).

Bundles must be either:

- securely double strapped i.e. each bundle must be cross strapped, both lengthways and widthways. This additional strapping serves the same purpose as bags and helps protect the bundles whilst in transit
- wrapped with polywrap (30 microns).

Postings that include bundles that are not strapped securely will be returned or subject to price adjustment. It is your responsibility to safeguard the hygiene of Mailing Items presented for posting – e.g. Mailing Items are free of moisture, clean and undamaged. The tension of any strapping applied to bundles should be such that there is no damage to the Mailing Items and that the edges of the Mailing Items are not damaged in any way when the strapping is removed and the edges of the Mailing Items are not torn or turned up.

When Mailing Items are of a single uniform thickness across their whole width and length, they must be faced and bundled the same direction.

Where bulky Mailing Items are not of a single uniform thickness across the whole width and length, they must be bundled in such a way that the bundle is level and squared off at the ends. If Mailing Items are thicker at one end the Mailing Items should be counter stacked with the top half of the bundle turned the opposite way to the bottom half. Address must still be facing upwards.

Elastic bands must not be used for holding bundles together. You are required to present bundles either brick stacked or column stacked in Containers.

3. Weight Limits

Bundles must not exceed the following weights: -

- 6.4kg each bundle must be stacked safely and securely in each York Container.
- individual Mailing Items with a weight up to 100gms, or flimsy in construction, must have a bundle height of at least 15cm to maintain rigidity and efficiency when being handled
- The volume of Mailing Items in each bundle must be maximised to ensure the minimum total number of bundles are presented for a single mailing, subject to sortation requirements, e.g. it is not acceptable to present 2 bundles for the same SSC each weighing 3KG, in this instance a single bundle of 6KG should be presented.

4. Labelling

Each bundle must be labelled as follows:

- unique bundle ID number

- UCID
- format
- your name or Access Licence Number
- customer type – DSA for operator access and CDA for customer direct access Customers –
- destination Office – Mail Centre name
- selection name – name of the Selection as listed in the Access Selection Files
- Access Selection Files SSC

For bundles held together with strapping, the label may comprise a simple carrier on top of the bundle and held in place by the strapping. The labels, which should be placed in the top right corner of the bundle may correspond to the dimensions of each Mailing Item and must be at least 125mm x 176mm. The text must be large enough to be highly visible (recommended 18 point or above). We will not supply this type of label.

Where strappex has been used to hold the bundle together it is preferred that the Delivery Address is fully obscured on the top Mailing Item. This allows the bundle label to be applied through or across the strappex if desired.

For bundles held together with polywrap the label should comprise a white adhesive label, of comparable size to the normal bag label (120mm x 50mm), applied to the outside of the polywrap. The label should be applied in such a position that it obscures the Delivery Address of the Mailing Item beneath the wrapping to avoid the bundle being perceived as a single Packet. We will not supply this type of label.

Standard bag labels may only be used if they can be affixed securely to the top of the bundle and it can be assured that the label will remain on the top of the bundle during transport. (Attaching labels to the strapping with bag ties is not acceptable for Health and Safety reasons unless the loose end of the bag tie has been clipped.) It is not allowed to place loose labels under strapping.

5. Printing labels onto Mailing Items for unbagged mailings

Where you wish to print labels directly onto items, or the top item of a bundle the following requirements apply to Mailing Items of the following sizes:

- Letters: minimum size of 229mm long, 165mm high and 1mm thick. i.e. C5 envelope format
- Large Letters: maximum size of 353mm x 250mm x 25mm thick.

The label content must meet the standard labelling requirements in all aspects i.e. size, content, element positioning, and formatting. The only difference from the standard requirements is that it is permitted to print the label details on the item or item enclosure.

A label outline border must not be printed around the label.

A 5mm clear zone must be provided around the 'label area'. Consequently, an area of 128mm x 58mm is required for the label and its clear zone as illustrated.

Figure 27: CFL requirements

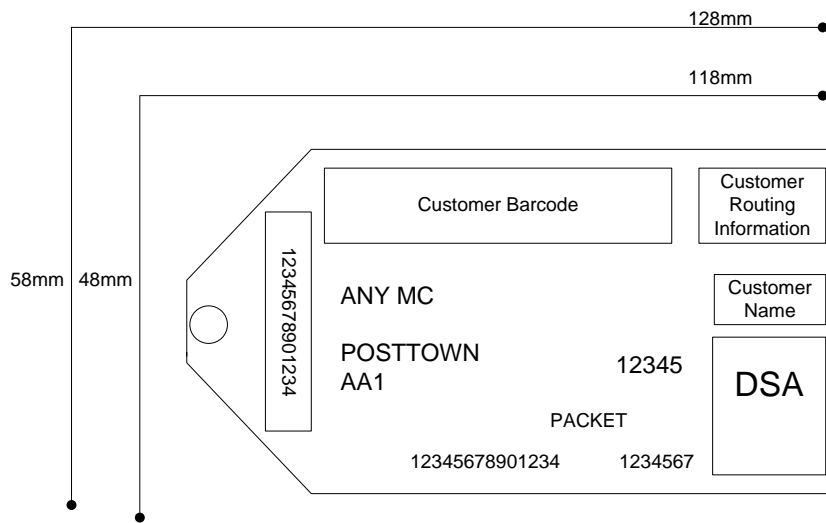

The label must be printed on a white background and in an area free from other printing.

The label must be positioned above and to the left of the Delivery Address block. Where the return address is on the front of the Mailing Items the label must be printed below the return address block. See figure 28.

Figure 28: Return address positioning

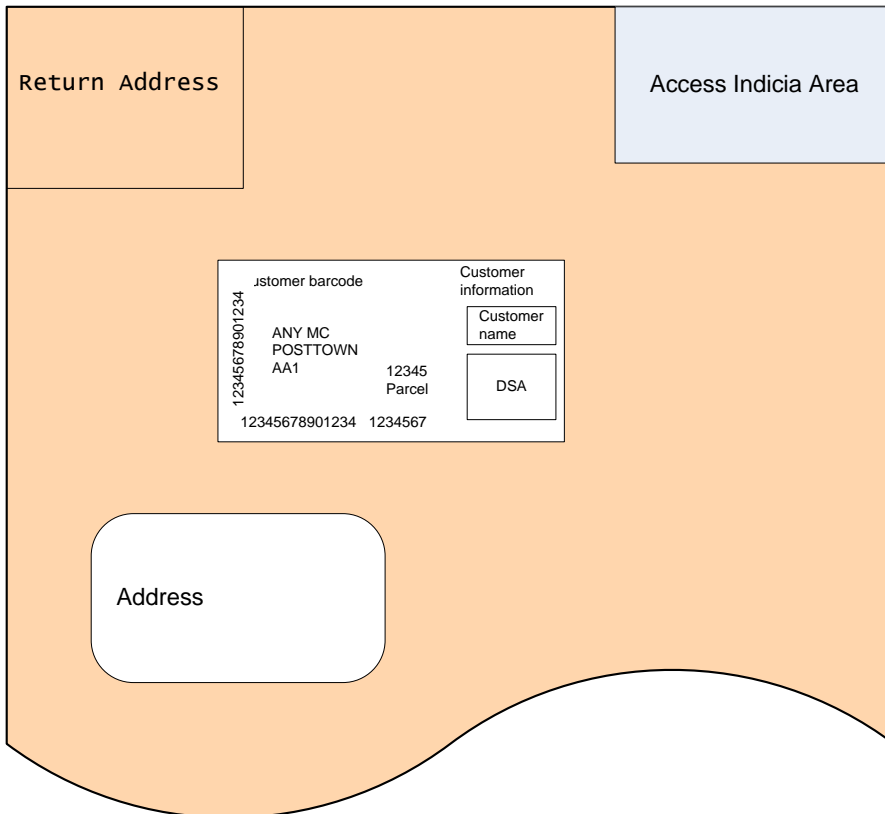

ROYAL MAIL WHOLESALE

Where the bundles are polywrapped, the current requirement to obscure the Delivery Address of the top Mailing Item with a carrier sheet/adhesive label over it remains. This is to ensure that the bundle is split before delivery and that all Mailing Items do not go to a single address. However, where bundles have been strapped, it is not mandatory to cover the top Delivery Address providing that the above labelling requirements are met.

It is preferred that only the Indicum, Delivery Address block, return address block and the label should be visible on the face of the Mailing Items but this is not a mandatory requirement.

Parcels to Jersey (JE) and Guernsey (GY), are excluded from being presented as strapped bundles for security and handling safety and must be presented in bags in accordance with [section 6.3](#)

Appendix E: Key National Posting (KNP)

1. Introduction

The information in this document is designed to define the process for managing together KNP; it describes the communication channels, the flow of information and the actions required by each link within the process.

This process applies to all Mailing Items posted using the 1400 or 70 Parcels Services and is in addition to and does not replace any existing processes for handling Mailing Items as described in this User Guide . The effectiveness of a KNP is largely dependent on the timeliness of the exchange of key information between, you and us.

2. Background

The KNP process is designed to ensure advance notice is provided for all postings that require additional planning and management because of their volume, size, shape or geographical bias.

The KNP process is used to raise the awareness of particular Postings to ensure these Postings are planned, communicated & executed to meet the product specification and Quality of Service in an efficient & cost effective manner to the benefit of all concerned.

Failure to provide the necessary information may result in Mailing Items not being delivered within the expected timescales, and we may manage the handling and delivery of Mailing Items to ensure excessive costs are not incurred.

3. Definition

A KNP is any Posting, which may cause operational challenges or difficulties and may not be successful or meet quality of service unless it is planned discretely from 'business as usual' Postings and the plans implemented.

It should be noted that individual Postings may not in themselves cause operational difficulties, but may contribute to such concerns when combined with other such Postings, or planned at specific seasonal times of the year. Therefore, if any Posting fits any of the criteria described at Annex A (see figure 29) the KNP process must be followed. We maintain the right to manage any Posting as a KNP if it is deemed to have an operational impact, or be exceptional due to its size, weight, or geographical delivery bias.

4. KNP process

A KNP must be communicated and raised at the earliest possible opportunity via the monthly meetings you have with us. The timeline will then be implemented by us both, and the exchange of information progressed to deliver an effective and efficient Posting. The time line is detailed in Annex B (see figure 30).

5. Entry Level

Volume is not the only determining factor; the key issue is one of workload and capacity in our and your networks. A common sense approach is applied to Postings that may reasonably be considered to be exceptional because of their volume, size, shape or geographical bias and/or show a significant spike in your normal posting pattern. Annex B (see figure 30) provides the timeline, and additional support is provided using the KNP impact chart contained Annex A. (see figure 29)

6. Documentation

In order to be able to manage the KNP effectively and efficiently you may be required to produce a separate docket for the KNP in the same format as your Posting Docket. If this is required, you must also produce a separate Manifest for the KNP in the same format as the Manifest or agreed Summary Manifest. These requirements will ensure the KNP is given discrete attention and that any changes in business as usual Postings do not impact on the planning and management of KNP.

For all KNP Postings, you must submit a fall to earth (FTE) of the posting profile on at least 7 days' notice prior to the Mailing Items being handed over to our Inward Mail Centres. The details required in the fall to earth are shown in Annex C (see figure 31). Any changes to the FTE must be notified immediately to us.

7. Access Slots

If additional Access Slots are required, then you must inform your Access Account Director and must apply for these at least 10 Working Days prior to the KNP being handed over to our Inward Mail Centres. Section 12.4 of the User Guides provides more information on booking ad-hoc/additional Access Slots.

8. Handover

If necessary we will allow the use of Letters of Authority for KNP and they must be presented and handed over separately to us for each Inward Mail Centre accessed.

Annex A - KNP/ELP Criteria

Mailing Items which you plan to handover that meet the criteria below must be notified to us a minimum of 4 weeks before the first date of handover our Inward Mail Centres to enable detailed operational planning to take place. (4 weeks has been specified as it is reasonable to expect that the details of the posting to be known at that point)

We will discuss and agree with you if the Posting requires the KNP process to be followed. A potential KNP needs to be raised at the earliest possible opportunity. If you fail to notify us of a KNP Posting in accordance with the timeline at figure 30 we may handle the Posting over a number of days; the number of days to be determined by us.

Figure 29: Annex A - KNP criteria

Key Criteria	
In addition to the total volume of Mailing Items being posted, other criteria may also determine if a posting is to be managed as a KNP, such as:	
<ul style="list-style-type: none"> • Mailing Items of an unusual size/shape or weight; • Mailing Items that do not fit through the average sized letter box as defined by the European Standards Commission (this can be obtained on request); • When a Business Reply Envelope (BRE) is included in the outward posting and there is an anticipated response level of more than 10,000 items for 5 consecutive days; • A Posting with a geographical bias, therefore, the operational impact of a posting with this profile will nearly always be considered for KNP status. This may include National Postings that may have a geographical bias as a result of the production order and handover of the Posting 	

Volume	Impact grid to be used as a guide for all Parcels Services					
	A3 Parcels			Parcels		
>1m	Red					
750k-1m	Red					
500k-750k	Red		Amber		Red	
250k-500k	Red	Amber	Red		Amber	Red
125k-250k	Amber		Green	Red		Green
0-125k	Amber		Green		Amber	
format	A3 Parcels			Parcels		
Impact	Geographical Bias	Unusual format	National	Geographical Bias	Unusual format	National
Sortation	1400 of 70	1400 of 70	1400 of 70	1400 of 70	1400 of 70	1400 of 70
Parcels Service	Manual	Manual	Manual	Manual	Manual	Manual

Key:

Red = KNP

Amber = Possible operational impact, therefore, KNP status considered. Please discuss with your Account Handler

Green = Not considered a KNP

Figure 30: Annex B – KNP timeline

Activity	Time before posting date	Date expected	Clarification of information required	Date complete
commencement date of posting	- 28 days		date to be confirmed - will be first handover at RM IMCs	
format and sortation of Mailing Items	- 28 days		weight & sortation level to be confirmed	
volume of Mailing Items & other criteria (see App. A above)	- 28 days		total volume and estimated volumes other criteria by Handover Day	
item weight and description	- 21 days		example Mailing Items (if available) and exact weight of item to be provided.	
response item	- 21 days		is a response item contained within Mailing Items	
return address	- 21 days		UK returns to sender address to be supplied.	
fall to earth for each Handover Day (in Excel format) This must match the forecast provided.	- 14 days		information required see Appendix C	
presentation and Containerisation of mail	- 14 days		Containers & presentation of mail to be confirmed	
book additional Access Slots	- 14 days		book any additional Access Slots via DocketHub	
ensure drivers and vehicles are on DocketHub	- 14 days		upload to DocketHub	
formal confirmation of posting dates	- 14 days		confirm dates and weights	
bag ties and bag labels	- 14 days		order additional supplies	
Containers	- 14 days		order additional supply	
include KNP in 7 day rolling forecast	-7 Working Days		upload into DocketHub	
include KNP in Pre-notification forecast	- 24 hours		upload into DocketHub	
upload KNP in separate 06:30 upload to DocketHub	By 06:30 am on Handover Day		upload into DocketHub.	
begin KNP and review	0			

You must provide detailed fall to earth in the format detailed below in EXCEL 2 weeks in advance. The total Daily Posting volume of Mailing Items handed over must be detailed by format, number of Mailing Items, number of Containers, sortation level, SSC, Postcode Delivery Office and Inward Mail Centre.

Figure 31: Annex C – KNP FTE

Date of handover	Format	No of items	No of Containers	Sortation level	SSC	Postcodes	Delivery Office	Inward Mail Centre
dd/mm/yy	Parcel	XX	XXX	1400	12345	XX1A	XXXXX	XXXXX

Appendix F: Zonal Option

1. Introduction

If you have opted for a Zonal Price Plan within your Contract you are required to meet certain additional presentation requirements. The following sections provide; the detail of those requirements, the additional software that is available to aid those requirements and the detailed pricing formula values.

2. What is a Zone?

We have analysed the c.11000 Postcode Sectors in the United Kingdom and have allocated each of these to a zone according to the criteria as per the table below.

Figure 32: Zone definitions

Zone	Definition
	Where DPD = Delivery Point density and BD = Business Density
A (Urban)	(BD > 10% and DPD >500) or DPD >1000
B (Suburban)	DPD <1000 >100
C (Rural)	DPD <100
D (London)	M25 Where the relevant 3 digit Standard Selection Code (SSC) is defined as "having more than 50% of its postal delivery volumes going to an area within the M25 boundary"

A full list of Postcode selections and zones can be found within the Access Selection Files on our Website www.royalmailwholesale.com

3. What is a Zonal Posting?

Mailing Items sent under a Zonal Price Plan are those where the fall-to-earth of the Mailing Items is not expected to meet the posting profile requirements of the National or Averaged Price Plans Geographic Posting Profile (NGPP). In order to price Zonal Postings we have developed Zonal Charges for each of the Services available.

Zonal Mailing Items are priced on any given day not only by the Mailing Items weight (dependant on weight band), format and Service but also by the number of Mailing Items at each Zone, for the same criteria.

You are required to analyse each Container at this level of detail and present it to us via DocketHub (see figure 34 Zonal Manifest). We will summarise this data for pricing purposes as presented on the Posting Docket and Invoice.

4. Mail Presentation

It is a requirement that all Mailing Items for a Zonal Posting carry the Zonal Indicator relevant to the Postcode sector of the corresponding address.

There are two options relating to the positioning of the Zonal Indicator on your Mailing Items: it may be positioned within the top right hand area of the address window immediately following the SSC (zone A, B, C or D) e.g. 53200 A; or, it may be preceded by the word "Zone" and be in a minimum font size of 10 point (e.g. Zone A).

Both options need to be positioned outside of any Clear Zones.

Figure 33: Zonal Indicator positioning

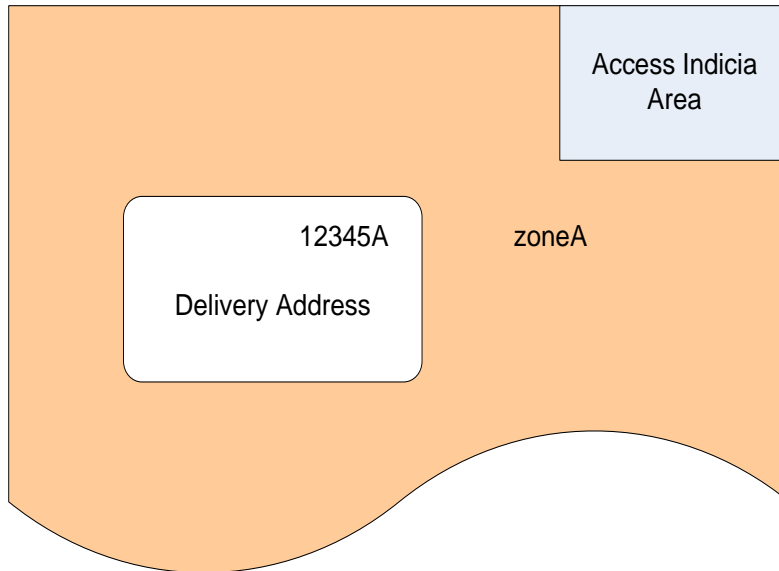

To facilitate this we have developed the Access Selection Files, which are available to download from our Website www.royalmailwholesale.com, which incorporate the Zonal Indicator and which will be updated monthly for new Postcode sectors. All other functionality remains as per the existing Access Selection Files.

The Access Selection Files are maintained by us and linked to our Delivery and Postcode databases in order to ensure the most up to date Postcode sector analysis is available for you to price Zonal Postings. We will notify registered users automatically when updates are available. It is mandatory to use the most up to date Version of the Access Selection Files. It is highly recommended, unless specifically requested as a mandatory update, that the most up to date Access Selection Files Release be used, to ensure mailing lists are priced correctly.

We conduct an annual review of Postcode sectors to Zones, which will be effected by publication of a new Release of the Access Selection Files. Use of this specific Release of these Access Selection Files is mandatory for all Zonal Postings.

For more information on these Access Selection Files, please refer to our Website at www.royalmailwholesale.com which includes a technical helpline number.

5. Bundles

Mail shall be bundled as per [section 6](#)

6. CFL

All mail presented under the Zonal Option must have the word 'zonal' clearly visible and legible on the CFL. For more details, please see [section 7](#).

7. Data Requirements

DocketHub

In addition to the standard data requirements for the DocketHub interface, the volume of Mailing Items at each Zone per Container will also be required. The DocketHub technical specification and User Guide can be found on our Website www.royalmailwholesale.com and includes the specific

additional coding requirements for the Zonal Option. This upload will generate a Zonal Manifest per figure 34.

Figure 34: Zonal Manifest

Site Manifest / Delivery Note										
Access Site:			Handover Date to Royal Mail:							
Address:			Account Number:							
Job Reference:			Account Name:							
			Docket Number:							
			Licence Number:							
Container ID	UCID	SSC	Postcode Area	Product Details	Zone	Items	Ave. Weight (g)	Total Weight (kg)	Declared Container Weight (kg)	Declared Container Items
<p>Please Note: This delivery note does not constitute acceptance that the above details are correct, as these details will be subject to Royal Mail revenue protection and mails verification checks. For the avoidance of doubt, this document only acknowledges the handover of mail items on the time date specified.</p>										
Royal Mail: (print)						Royal Mail use:				
Royal Mail: (signature)						Handover date to Royal Mail:				
						Arrival Time to Royal Mail:				

8. Pricing

The detailed Manifest data per Container will be summarised for pricing and invoicing purposes at the level of Service, format, average item weight, and number of Mailing Items per Zone.

The pricing methodology and the current prices for the Zonal option can be found on our Website www.royalmailwholesale.com and within the pricing Schedule of your Contract.

Where the address data on a Mailing Item does not have the Postcode selection in sufficient detail to identify a Zone, you must declare such Mailing Items as Zone Z, except for Mailing Items whose delivery destination are in the London Zone, which you must declare as Zone D. Zone Z Mailing Items will be charged at Zone C prices. It is your responsibility to upload the Mailing Items to the correct Zone.

9. Zonal Pricing calculator

In order for you to estimate the cost of a Zonal Posting, we have developed a pricing calculator that will provide indicative prices in advance of actual mail production. The calculator is available on our Website www.royalmailwholesale.com.

10. Revenue Protection

Where the additional Zonal presentation requirements are not being met, we may refuse those postings and apply the appropriate corrective actions set out in Schedule 2 of the Contract [section 15](#) of this User Guide.

Appendix G: Definitions and Interpretations

The following is an explanation of words and phrases used in this User Guide which have a specific meaning:

Access Selection Files	data files controlled and made available by us which enables the sortation by Postcode of Mailing Items in to groupings which we call Selections, as described in Appendix B to the User Guide;
Access Slot	the period within the Access Window for an Inward Mail Centre agreed by us and you in line with the User Guide;
Access Window	the hours between 07.30am and 12 noon on any Working Day;
ALPS	an auto level packet sleeve as more fully described in Schedule 14: ALPS Exchange;
Charges	the charges we may make under this Contract, including Postage, Surcharges and Profile Surcharges;
Client Report	the client report generated by us in accordance with section 9 of the User Guide as varied from time to time;
Consolidated Posting	the total number of Mailing Items which you hand over on any single Working Day to us to convey and deliver and which has not been identified by you as a UCID Posting;
Container	a Royal Mail bag, ALPS or any other primary container type approved by us from time to time;
Credit Account	the credit account operated in line with clause 11;
Customer Access Indicator	your marks, impressions or other devices that may, subject to our prior approval, be shown on each Mailing Item which is to be conveyed and delivered under this Contract. These marks, impressions and devices are initially as set out in Schedule 4 (subject to operational testing) but may be changed by agreement between you and us (acting reasonably);
Customer Entity	a discrete posting unit or third party that you wish to be recognised for the purpose of handing over Mailing Items as UCID Postings in line with this Contract;
Delivery Address	the address to which a Mailing Item is to be delivered and which must consist of an addressee and a geographic address of the UK displayed on the Mailing Item;
Daily Posting	the total amount of Mailing Items handed over by you on any single Working Day to us to deliver under this Contract;
Delivery Point	a postal address (business or residential) to which we deliver Mailing Items;

Discrete Customer Posting	a Daily Posting specific to a Customer's individual Price Plan(s) posted under this Contract;
DSACC	Downstream Access Central Control is our central team who manage the day to day issues and communication of all operational issues relating to this Contract;
Early Release Schedule	the terms of Schedule 15: Early Release;
Exceptions	Variance to the Posting Docket of Mailing Items handed over by you on Handover Day ;
Handover Day	the Working Day on which a Daily Posting is handed over at the Inward Mail Centres;
Indicium	the marks placed on a Mailing Item in line with the User Guide comprising the Royal Mail Access Indicator and if required by you the Customer Access Indicator;
Inward Mail Centre	one of our inward mail centres as detailed on our Website;
Key National Posting (KNP)	a posting of exceptional size, volume, shape or geographical bias which requires specific planning to enable the Service Standard to be met;
Mailing Item	a Parcel or A3 Parcel, the dimensions of which are set out in this User Guide;
Manifest	a declaration by you giving details of a Posting, in line with this User Guide;
Mixed Weight	an optional form of presentation of Mailing Items which allows you to mix different weight bands in the same Container in line with the Mixed Weight Schedule;
National Option	National Price Plan One (SSCs);
Operational Contact	has the meaning set out in clause 4 of the Contract Details;
Originating Customer	a posting customer for whom an Operator hands over Mailing Items to us;
Parcel	a Mailing Item that meets the specifications for a parcel as set out in the User Guide from time to time;
Parcels Services	the services provided by us as listed in Figure 1 of the User Guide;
Postage	the amount payable by you to us for Mailing Items handed over in a Daily Posting;
Postal Operator	a postal operator, as defined in the Act;
Postcode	an alphanumeric code owned and developed by us, and allocated by us, to identify a Delivery Point or group of Delivery Points;
Postcode Area	the first (either one or two) letter(s) of a Postcode, which is used to identify a geographical area for Mailing Items to be delivered;

Postcode Sector	the first three, four or five alphanumeric digits of an outward Postcode, which is used to identify a geographical area for Mailing Items to be delivered;
Posting	the total amount of Mailing Items each day which you hand over to an individual Inward Mail Centre for us to convey and deliver;
Posting Docket	the certificate containing details of Postings (which we need to calculate the Postage), described in the User Guide;
Posting Entity	a posting site or consolidation machine used to prepare Mailing Items for handover to us as a UCID Posting under the terms of this Contract;
Price Plan	the Price Plan which applies to your Contract, set out in Schedule 3 of your Contract;
Revenue Protection	our process of sampling and checking of your Mailing Items on hand over to us;
Royal Mail Access Indicator	our marks, impressions or other devices shown on each Mailing Item which is to be conveyed and delivered under this Contract. These marks, impressions and devices are initially as set out in Schedule 4 of the Contract but may be changed by us (acting reasonably) in line with clause 13.2.1;
Royal Mail Group	each and any subsidiary or holding company of Royal Mail Group Limited and each and any subsidiary of a holding company of Royal Mail Group Limited;
Service Standard	has the meaning set out in Part A of Schedule 2 of the Contract;
Standard Selection Code	The unique numeric code that identifies the selections as used in the Access Selection Files;
Summary Manifest	is a physical paper summary of the total number of containers by Container type handed over at an Inward Mail Centre;
Surcharge	(in respect of a Mailing Item) an amount charged to cover our reasonably incurred costs in remedying any non-compliance of that Mailing Item with the requirements of the Contract;
Tolerance	has the meaning set out in Part C of Schedule 2 of the Contract;
UCID	the optional unique customer identifying number assigned by you to each of your Originating Customers, Customer Entities and Posting Entities and used and displayed as specified in Schedule 2 of the Contract and the User Guide;
UCID Posting	the total amount of Mailing Items which you hand over on any single Working Day to us to deliver which has been identified by the use of a UCID as discrete to an Originating Customer, Customer Entity or Posting Entity;

Under Volume Container	a Container which is not filled with the minimum items by you in line with the requirements set out in the User Guide;
User Guide	the document entitled Parcels Services for Inward Mail Centres which is published by us, as may be changed under clause 13 of the Contract;
Working Day	any day which is not a Sunday, bank holiday, public holiday or a non-service day approved as such by the Regulator;
York	our caged trolley(s) used to move or transport bags of Mailing Items;
Zonal Indicator	the indicator of the Zone to which a Mailing Item is to be delivered under the Zonal Price Plan;
Zonal Option	the Zonal Price Plan as applicable to your Contract;
Zonal Posting	a Posting under the Zonal Price Plan;

Appendix H: Prohibited Items, Restricted Items and Valuables.

1. What can and cannot be contained within an item

There are some items that we cannot carry through our Access postal network for legal or safety reasons. Items that we cannot carry through our Access postal network because they are forbidden further to international conventions and/or UK laws and regulations (illegal in the post, illegal by law or considered environmental waste) are known as **prohibited items**. Some other items can only be carried under certain circumstances detailed in our lists - these are known as **restricted items**. We also limit our liability on **valuable items** and request you do not to send valuables through our Access postal network. This appendix details the current lists of **Prohibited Items, Restricted Items** and **Valuables** and are the same lists that are published on our Website, www.royalmailwholesale.com. These lists may be amended from time to time in line with legal requirements or safety practises.

Prohibited Goods list:



Restricted Goods list:



2. Valuables.

Valuables are items you cannot send in the post and defined as money and jewellery.

1. Any item that Jewellery (including diamonds and precious stones).
2. Watches (the cases of which are made totally or mainly of precious material).
3. Any precious material that has been made to add value to the raw material, including coins used for ornament.
4. Any similar articles (to 1-3 above) with a value other than the value of the workmanship and/or an intrinsic value (when used in relation to the content of an item, means that it has an inherent monetary value relating to its essential nature).
5. Money (including, coins, bank notes, postal orders, cheques; unused postage and revenue stamps and National Insurance stamps; exchequer bills, bills of exchange, promissory notes and credit notes; bonds, coupons and other investment certificates; and coupons, vouchers, tokens, cards, stamps and other documents that can be exchanged for money, goods or services).