

## Mailmark Letters – Specification Requirements

The document sets out physical design, Indicium, addressing, barcoding and other Royal Mail Mailmark specifications that are required when posting Letters using Mailmark.

The document is designed to ensure that Royal Mail Letter processing machines can process and read Letters effectively at high speed, without the need for manual or other intervention. Each specification requirement set out in this Appendix M has been assessed and is categorised as either ‘Mandatory’ (M), or ‘Recommended High Risk’ (H) or ‘Recommended Low Risk (L)’:

- Letters that fail to meet the ‘Mandatory’ requirements are regarded as unmachineable and are very likely to have Surcharges applied.
- Letters which fail to meet the requirements that are identified as ‘Recommended - High Risk’ have a higher likelihood of performing poorly through our processing machines. Letters that fail to meet these requirements are more likely to have Surcharges applied and may become damaged in our processing machines.
- Letters which fail to meet the requirements that are identified as ‘Recommended - Low Risk’, may perform poorly through our processing machines. However, the risk is lower than that posed by failure to meet the ‘Recommended High Risk’ specifications and there is less chance of Letters being damaged or Surcharges being applied.

We have provided guidance footnotes that explain the risks associated with not meeting the ‘Recommended’ requirements.

At the bottom of the document we have also provided all of the Figures which are referenced throughout the document and which provide illustrative examples of the specification requirements.

### 1. Physical

Category		Specification Requirement	M/R
<b>Size &amp; Shape</b>	<b>Shape</b>	Rectangular or square with straight sides and 90° corners	M
	<b>Orientation</b>	Landscape or portrait	M
	<b>Size</b> (H x L x D)	<u>Rectangular</u> Minimum – 90mm x 140mm, Maximum – 165mm x 240mm <u>Square</u> Minimum – 140mm x 140mm, Maximum – 165mm x 165mm	M
	<b>Thickness</b>	Minimum – 0.25mm, Maximum – 5mm	M
	<b>Weight</b>	Maximum – 100g	M
	<b>Content / Inserts</b>	<ul style="list-style-type: none"> <li>• One or two standard size staples (maximum 24mm x 6mm) or paper clips (maximum 23mm long) may be inserted in the Letter.</li> <li>• Other metal objects such as keys, pens, coins etc. must not be placed in the Letter.</li> <li>• Inserts other than paper that are placed in an envelope should be fixed in position and attached to the largest paper insert. e.g. bank cards.</li> <li>• The spines on booklet inserts should be located on the reference edge <sup>2</sup>.</li> </ul>	M  H <sup>1</sup>  L <sup>3</sup>
	<b>Lateral Movement</b>	<p>There are limitations on the lateral movement space that the insert may have. These are dependent upon the thickness of the Letter and apply to the largest paper insert (see Figure 1):</p> <ul style="list-style-type: none"> <li>• Where the thickness is 2mm – 5mm the lateral movement should be no more than 20mm.</li> </ul>	H <sup>4</sup>

<sup>1</sup> Lowers the risk of moving inserts breaking through the Letter edges.

<sup>2</sup>The reference edge is a fold on a particular edge of the Letter, which enables it to be processed through the machines efficiently. The reference edge is the edge beneath the address for landscape rectangular and square Letters, and the long edge to the left of the address for portrait Letters.

<sup>3</sup> This reduces the potential for mail damage following jams.

Category		Specification Requirement	M/R
		<ul style="list-style-type: none"> <li>Where the thickness is 0.25mm – 2mm, the lateral movement should be no more than 30mm.</li> </ul>	L <sup>4</sup>
	<b>Flexibility</b>	Each Letter must be capable of being transported around a pulley with a radius of 140mm with a max force of 26 N (See Figure 2).	M
<b>Envelope Construction &amp; Design</b>	<b>Material</b>	Envelopes must be made from paper only and have NO open apertures <sup>5</sup>	M
	<b>Flaps</b>	The opening flap may fold to either the back or the front of the Letter. Where the flap folds to the front (address side) of the Letter, its edge should not fall within the Tag Codemark clear zone.	L <sup>6</sup>
	<b>Sealing</b>	<ul style="list-style-type: none"> <li>Adhesives used must be dry and must not leak onto the open surface of the Letter.</li> <li>Letters must not be stuck or caught together.</li> <li>Envelopes should be securely sealed on the front, back, and all edges.</li> <li>Letters presented in trays should be sealed to within a minimum of 35mm from the fold of the envelope flap, and 35mm from the envelope sides (see Figure 3).</li> <li>For all other Letters, the flap should be sealed to within a minimum of 35mm from the fold of the envelope flap, and 25mm from the envelope sides (see Figure 4).</li> </ul>	M M H <sup>7</sup> L <sup>8</sup> L <sup>8</sup>
	<b>Paper Weight</b>	<ul style="list-style-type: none"> <li>Minimum – 70gsm for envelopes</li> <li>Recommended minimum 200gsm for postcards</li> </ul>	M H <sup>7</sup>
	<b>Opacity</b>	The paper used should be at least 85 % opaque (BS ISO 2471 - Paper and board. Determination of opacity)	H <sup>9</sup>
	<b>Absorbency</b>	The paper used should have an absorbency of 15–35 gsm of water in 1 minute (BS EN 20535 - Paper and board. Determination of water absorptiveness.)	H <sup>10</sup>
	<b>Porosity</b>	The paper used should have a porosity value of less than 700 ml per minute (BS 6538-2 - Air permeance of paper and board.)	L <sup>11</sup>
	<b>Finish – Digitally Printed Mail</b>	<p>When digital printing is used for mail, the pigment may rub off, transfer to adjacent surfaces (inserts and the envelope), crack, and become marked both during the manual and automated handling processes. The application of an ultra violet (UV) cured varnish has been found to reduce the wear to digitally printed mail items. This provides a protective coating over the pigment. It should only be applied to the non-address side of the Letter as the characteristics of the varnish may make the mail unmachineable if applied to both sides<sup>12</sup>.</p> <p>The pressure exerted on the Letter during automated processing may cause colour offset on digitally printed items. Therefore, it is recommended that there should be no off-set of print or colour transfer when the item is exposed to a pressure of 3.43kPa (35g per cm<sup>2</sup>). This equates to a weight of 8.5kg spread over the surface of a DL envelope, and 13.5kg for C5 envelopes.</p>	L <sup>13</sup>
	<b>One-Piece Mailer</b>	See One-Piece Mailer Specification (including one-piece mailers, wrap mailers, coupon mailers, feature mailers, and machineable postcards) in section 2.6.1.	-
	<b>Perforated Mailers</b>	See Perforated Mail Specification (including perforations, zip tie, and pressure seal envelopes) in section 2.6.2.	-
	<b>Do Not Redirect</b>	See separate Do Not Redirect Specification	-

<sup>4</sup> Where the Letter thickness is variable and lateral movement is high, there is an increased risk of the Letter content being separated from the envelope or wrap.

<sup>5</sup> Note that an unwrapped Mailmark Letter sized item will be treated in the first instance as an unwrapped Large Letter MM and not a manual letter.

<sup>6</sup> Tag codemark reading supports Mailmark reporting.

<sup>7</sup> This ensures that the Letter is strong enough to withstand the rigours of mechanical and manual handling.

<sup>8</sup> This may result in the unsealed portion of the flap being torn during processing.

<sup>9</sup> This facilitates Mailmark, address, and Indicia reading.

<sup>10</sup> This facilitates the application of codes and artwork to the Letter (i.e. the ink soaks in and does not rub off).

<sup>11</sup> This facilitates the singulation of the mail at machine infeed (i.e. fewer double fed Letters and missorts).

<sup>12</sup> They may have 'window-like characteristics' that reduce mechanical handling capability, increase static cling, and compromise codemark printing

<sup>13</sup> The impact of this is limited to the artwork and it is highly unlikely to result in poor processing performance.

Category		Specification Requirement	M/R
	Logos & Advertising	<ul style="list-style-type: none"> <li>Any logo or advertising slogan printed on the Letter should not look like an address or include a geographical location, country or a Royal Mail bag or bundle label.</li> </ul>	L <sup>14</sup>
		<ul style="list-style-type: none"> <li>Slogans where the company name contains the words 'Return', 'Address' and 'Undelivered' should be avoided.</li> </ul>	L <sup>14</sup>
Window	Fixing	<ul style="list-style-type: none"> <li>Envelopes with apertures must have a window film covering the aperture, and the film must be securely sealed to the inside of the envelope on all sides of the aperture.</li> </ul>	M
		<ul style="list-style-type: none"> <li>The Delivery Address must be visible through the window.</li> </ul>	M
Window Cont.	Fixing cont.	<ul style="list-style-type: none"> <li>The window film should be flat and fixed evenly across the surface area it is in contact with.</li> </ul>	H <sup>15</sup>
		<ul style="list-style-type: none"> <li>The window film should be robust enough not to become creased, crumpled or otherwise deformed.</li> </ul>	H <sup>15</sup>
	Number	There should be no more than 2 windows on the front of the Letter (or alternatively 1 on the front and 1 on the back).	L <sup>16</sup>
	Size	The window(s) on the front of the Letter must take up no more than 50% of the surface area.	M
	Size & Shape	<ul style="list-style-type: none"> <li>Front windows should be rectangular (with rounded corners), or circular and no more than 85mm in diameter (see Figure 5).</li> </ul>	L <sup>15</sup>
		<ul style="list-style-type: none"> <li>Where there are both front and back windows, the back window should be no more than 48mm in diameter and centred 31mm, plus or minus 2mm up from the bottom edge of the Letter.</li> </ul>	L <sup>15</sup>
	Position	<ul style="list-style-type: none"> <li>Windows on the front of the envelope must avoid the indicia area and the codemark clear zones, and must be located at least 15mm from the top, left and right edges, and at least 18mm from the bottom edge (See Figure 9 to Figure 12).</li> </ul>	M
<ul style="list-style-type: none"> <li>Windows on the back of the Letter must be at least 18 mm from the bottom edge of the Letter, and be at least 15mm from the edge for the remaining three sides (See Figure 9 to Figure 12).</li> </ul>		M	
Gloss	The maximum gloss value for the window should not exceed 150 when measured at 60°, in accordance with American Standard Test Method (ASTM) 2457.	H <sup>16</sup>	
Haze	The maximum haze value for the window should not exceed 75% in accordance with (ASTM D1003-00 Procedure A (Hazemeter)).	H <sup>16</sup>	

<sup>14</sup> This will reduce any potential for address reading errors.

<sup>15</sup> This ensures that the Letter is strong enough to withstand the rigours of mechanical and manual handling, and facilitates Mailmark and address reading.

<sup>16</sup> This facilitates Mailmark and address reading.

## 2. Network Access Indicum and Customer Access Indicator

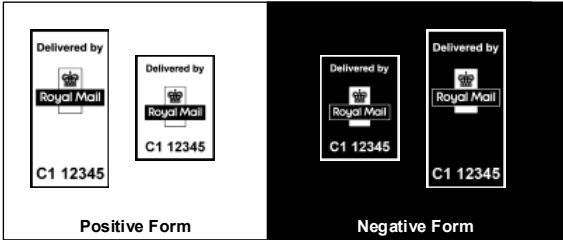
Category		Specification Requirement	M/R
Indicia	General	<ul style="list-style-type: none"> <li>All Letters must carry an approved Indicum which has been agreed by Royal Mail and the customer.</li> <li>Only one Indicum must be printed on the Letter.</li> </ul>	M M
	Location	The Indicum must be located on the front of the Letter, above and to the right of the Delivery Address and in the top right corner of the Letter in the Indicum area. This area is 75mm long & 40mm high (see Figure 9 - Figure 12).	M
RM Mail Access Indicator - PPI	Access PPI	 <p>The image shows two forms of the Royal Mail Access Indicator. On the left, labeled 'Positive Form', the indicator is printed in dark ink on a light background. It consists of a crown logo above the text 'Delivered by Royal Mail' and the alphanumeric code 'C1 12345'. On the right, labeled 'Negative Form', the indicator is printed in white on a dark background with the same elements.</p>	
	Indicum Size	<ul style="list-style-type: none"> <li>The small Indicum is 20mm high x 15mm wide (see Figure 6)</li> <li>The large Indicum is 30mm high x 15mm wide (see Figure 6)</li> <li>The Indicum must not be scaled.</li> </ul>	M M M
	Clear Zones	<ul style="list-style-type: none"> <li>A clear zone of 5mm must be provided to the left of the PPI.</li> <li>A clear zone of 5mm, plus or minus 2mm should be provided above, below, and to the right of the PPI.</li> </ul>	M L <sup>17</sup>
	Indicum Format / Colour	<ul style="list-style-type: none"> <li>Where the Indicum is in positive colour form, it will be printed in dark colour on a light-coloured substrate</li> <li>Where the Indicum is in 'negative' colour form, it will be printed in white on a dark coloured substrate.</li> </ul>	M M
	Indicum Printing	<ul style="list-style-type: none"> <li>All elements should be sharp, solid and distinct.</li> <li>The Indicum should be printed at a minimum resolution of 300dpi.</li> <li>Where the Indicum is darker than the background, the Indicum contrast on homogeneous backgrounds should be at least 20%, and at least 40% for inhomogeneous backgrounds.</li> <li>Where the Indicum is lighter than the background, the Indicum contrast on homogeneous backgrounds should be at least 80%, and at least 60% for inhomogeneous backgrounds.</li> </ul>	H <sup>18</sup> H <sup>18</sup> H <sup>18</sup> H <sup>18</sup>
	Indicum Skew	The skew should be no more than plus or minus 15° from the horizontal axis.	L <sup>17</sup>
	Location	This must be located 5mm to the left of the Royal Mail Access Indicator.	M
Cust. Access Indic.	Shape	<ul style="list-style-type: none"> <li>The Customer Access Indicator associated with the 20mm high and 15mm wide PPI Indicum must be no more than 20mm high and no more than 50mm wide.</li> <li>The Customer Access Indicator associated with the 30mm high and 15mm wide RM Access Indicum must be no more than 30mm high and no more than 50mm wide.</li> </ul>	M M
	Content	Any words used within the Indicator must be printed using a font size of at least 10 points.	M
	Clear Zones	A clear zone of 5mm, plus or minus 2mm should be provided above, below, and to the left of the Indicator.	L <sup>19</sup>
	Stamp-Like Indicia	See Stamp-Like Indicia Specification.	-
	Digital Stamp	See Digital Stamp Specification.	-

<sup>17</sup> The Indicia may facilitate the orientation of the Letter in the event of the Mailmark code not being read.

<sup>18</sup> This ensures that the Indicia is human readable.

<sup>19</sup> This is a preference that has no impact on mail processing.

### 3. Addressing

In this section, Mandatory requirements ensure that sufficient address content is provided to enable Royal Mail to read the address, and to deliver the Letters to the correct address. Recommended requirements enable effective processing when Letters cannot be processed against a Mailmark code.

Category		Specification Requirement	M/R
Delivery Address	Delivery Address Components	Mailer Defined Information VJC100 (if required) Addressee Ms A N Other ] Organisation Royal Mail ] Delivery Thoroughfare 185 Farringdon Road ] Address Locality London ] block Postcode EC1A 1AA ]	M
	General	<ul style="list-style-type: none"> <li>Only one Delivery Address must be printed on the Letter.</li> <li>The Delivery Address must be printed on the front of the Letter, on the same side and in the same orientation as the Indicia.</li> <li>No other addresses and nothing else that can be construed as looking like a Delivery Address must be printed on the Letter (with the exception of the Return Address).</li> <li>It may be wholly printed in English, or wholly in Welsh where a Welsh address is provided in PAF. The inclusion of addresses printed in a combination of English and Welsh is not permitted.</li> </ul>	M
			M
			M
			M
	Mailer Defined Information (Optional)	<ul style="list-style-type: none"> <li>Mailer Defined Information (MDI) may optionally be included as an additional single line immediately above the addressee name. It must not include a barcode of any kind.</li> <li>The mailer defined information should be in a typeface (not underlined) and may comprise letters, numerals, punctuation marks, and ideograms in a single line above the addressee e.g. a reference number or SSC.</li> <li>The mailer defined information should be left justified and aligned to the rest of the Delivery Address block.</li> <li>The content may be of a different font and size to the other Delivery Address block elements.</li> <li>The line spacing should be consistent with the rest of the Delivery Address block.</li> <li>The length of the mailer defined information should not exceed 64 characters.</li> </ul>	M
L			
L			
L			
L			
Content	<ul style="list-style-type: none"> <li>The Delivery Address must be a PAF address that includes at least one premise element, one thoroughfare element, one locality element <sup>20</sup>, and the postcode.</li> <li>A maximum of 2 lines of addressee information may be included above the PAF address.</li> </ul>	M	
		L	
Delivery Address	Content Cont.	<ul style="list-style-type: none"> <li>The number of characters per line of the delivery address block should not exceed 64 characters (including spaces).</li> <li>No counties or UK countries should be included within the Delivery Address block.</li> </ul>	L
			L
	Structure & Format	<ul style="list-style-type: none"> <li>The Delivery Address must be provided as a 'block' of left justified text with uniform line spacing (1-4mm) and with no blank lines.</li> <li>Each individual element of the address must be on a separate line. Note that the house number and the street name must always be printed on the same line.</li> <li>The Postcode must always be printed in 'UPPER CASE', and must be on the last line of the Delivery Address.</li> <li>There should be a gap of 1-2 spaces between the 2 parts of the postcode.</li> <li>The posttown may precede the postcode on the last line of the address if they are separated by 1-2 spaces. i.e. London EC1A 1AA.</li> <li>Only punctuation that is included with the PAF address should be included, or alternatively all punctuation may be removed.</li> <li>The Delivery Address should be printed in 'Title Case' (preferred) or 'UPPER CASE'.</li> <li>The word spacing should be 1-2 spaces and no more than 5mm.</li> <li>The Delivery Address block skew should be no more than plus or minus 5°.</li> </ul>	M
			M
			M
			L
			L
			L

<sup>20</sup> Where there is both a locality and a post town in the corresponding PAF record it is recommended that both are included;



Category		Specification Requirement	M/R
	Preferred Fonts	<ul style="list-style-type: none"> <li>A Single font should be used for the whole Delivery Address block and this should be printed using : <ul style="list-style-type: none"> <li>10-12pt font</li> <li>Normal character spacing</li> <li>Pitch set at 10-12 characters per inch.</li> </ul> </li> </ul>	L
		<p><u>Preferred Non-Proportionally Spaced Fonts are :-</u>  Courier, Courier New, Letter Gothic, Lucida Console,  Lucida Sans Typewriter, OCR B, Word Gothic</p> <p><u>Acceptable Proportionally Spaced Fonts are :-</u>  Arial, Avant Garde, Calibri, Estrangelo Edessa, Eurostile, Frankfurt Gothic,  Franklin Gothic (Book), Gautami, Geneva, Gill Sans, Helvetica, Latha, Lucida  Sans, Mangal, News Gothic MT, Optima, Ravi, Shruti, Trebuchet MS,  Tunga, Univers, Verdana</p>	L
	Fonts - General	<p>Any fonts that are used should be simple and easy to read. The following recommended specifications should be followed:</p> <ul style="list-style-type: none"> <li><i>Italic</i>, <b>bold</b>, pseudo script, serifs, computer zero (Ø) and <u>underlining</u> should be avoided.</li> <li>There should be clear vertical gaps of at least 0.25mm between extremities of adjacent characters.</li> <li>Height: 2mm min, 7mm max, Width: 7mm max</li> <li>Ratio of lower case height (b) to 'UPPER CASE' height (a) of between 2:3 and 3:4; and ratio of width (c) to height (a) of approximately 2:3. (See Figure 7)</li> <li>Character quality should be complete, clear and of high resolution, with individual stroke having a uniform thickness of 8% - 16% of the height of the character.</li> </ul>	H H H H H
	Print Quality	<ul style="list-style-type: none"> <li>The Delivery Address block MUST be printed using a dark colour (preferably black) on a light background.</li> <li>The paper opacity value should be at least 85 % (BS ISO 2471 - Paper and board. Determination of opacity (paper backing)).</li> <li>The contrast ratio for addresses printed on envelopes should be at least 50 % (window inserts 55%).</li> <li>Print quality must be such that characters are not blurred, smudged, deformed, or incomplete.</li> <li>There must be no splashing or ink spatter around the characters.</li> <li>We recommend that you regularly check the quality of your print output for clarity.</li> </ul>	M L L L L L
	Delivery Address Cont.	Location	<ul style="list-style-type: none"> <li>The Delivery Address block must be positioned on the front of the Letter below and to the left of the Indicia (see Figure 9 to Figure 12).</li> <li>The Delivery Address block must not be printed in the Indicia Area, or in the border area: <ul style="list-style-type: none"> <li>Landscape - 40mm top 15mm left and right, &amp; 18mm at the bottom,</li> <li>Portrait - 40mm top, 18mm left, 15mm right and bottom.</li> </ul> </li> <li>The Mailmark code must be at least 2mm from the Delivery Address block.</li> <li>The Delivery Address block should not be printed over the edge of the envelope flap.</li> <li>With the exception of the Mailmark code, a clear zone of at least 5mm is required around the Delivery Address block (including the MDI). No text, patterning, or graphics must be printed within the Delivery Address block and its clear zones. (See Figure 8)</li> <li>The last line of the Delivery Address block should always be at least 50mm from the top edge of the Letter.</li> <li>The Delivery Address block should not encroach into the tag codemark clear zone. (See Codemark Clear Zones).</li> </ul>

Category		Specification Requirement	M/R	
	<b>Window Clear Zone</b>	Where window envelopes are used, a minimum clear zone of 2mm within the window and 3mm on the envelope should be used. The clear zone requirements apply always, including after the Letter is tapped on all four edges to induce maximum insert movement. i.e. The whole of the PAF Delivery Address should always be visible.	L	
Return Address	<b>Return Address Example</b>	<b>Return Address</b> <b>Royal Mail</b> <b>Rowland Hill House</b> <b>Swindon</b> <b>SN3 5TQ</b>	M	
	<b>General</b>	<ul style="list-style-type: none"> <li>Only one return address must be printed on the Letter.</li> <li>Nothing else that looks like a return address must be printed on the Letter.</li> <li>The return address may be printed in English or Welsh (where provided in PAF). The inclusion of return addresses printed in both English and Welsh is not permitted.</li> </ul>	M M M	
	<b>Content</b>	<ul style="list-style-type: none"> <li>The return address must be prefixed with the words Return Address.</li> <li>The return address must be a PAF address that includes a premise element, thoroughfare element, locality, and the postcode.</li> <li>The addressee information must be included on the second line of the return address block.</li> <li>The number of characters per line of the return address block should not exceed 64 characters (including spaces).</li> <li>No counties or UK countries should be included within the return address block.</li> </ul>	M M M L L	
	<b>Structure &amp; Format</b>	<ul style="list-style-type: none"> <li>The return address must be provided as a 'block' of left justified text with uniform line spacing (1-4mm) and with no blank lines.</li> <li>The return address must be printed in 'Title Case', with the exception of the Postcode that must always be printed in 'UPPER CASE'.</li> <li>Each individual element of the address must be on a separate line. Note that the house number and the street must always be printed on the same line.</li> <li>The Postcode must be printed on the last line of the address or may be printed on the same line as the posttown (with a gap of 1-2 spaces).</li> <li>Only punctuation that is included with the PAF address should be included, or alternatively all punctuation may be removed.</li> <li>The word spacing must be no more than 5mm.</li> <li>The return address block skew must be no more than plus or minus 5°.</li> </ul>	M M M M M M M	
	<b>Fonts</b>	<ul style="list-style-type: none"> <li>Letter Gothic or Lucida Console font must be used for the whole return address and this must be printed using: <ul style="list-style-type: none"> <li>10-12pt font (12pt preferred)</li> <li>Normal character spacing</li> <li>Pitch set at 10-12 characters per inch.</li> </ul> </li> </ul>	M	
	<b>Print Quality</b>	The same specifications which apply to the Delivery Address must be met.	M	
	Return Address Cont.	<b>Location</b>	The return address must be either located: <ul style="list-style-type: none"> <li>On the back of the Letter and centred within the top 40mm. This is the preferred location as it avoids any confusion with the Delivery Address block (See Figure 13).</li> <li>On the front of the Letter in the top left corner (with no element closer than 75mm to the right edge) (See Figure 14), and no closer than 12mm to the Delivery Address.</li> </ul>	M
		<b>Clear Zones</b>	<ul style="list-style-type: none"> <li>No text, patterning, or graphics must be printed within the return address.</li> <li>There must be a clear zone of 5mm around the return address.</li> </ul>	M M

#### 4. Mailmark Code

Category		Specification Requirement	M/R
General	General	<ul style="list-style-type: none"> <li>Only one <b>Mailmark</b> 2D code or 4-state barcode must be printed on the Letter (the only exception being 4-State Consolidator Barcode which may be printed onto Letters that bear another Mailmark code).</li> <li>The Mailmark 2D code or 4-state barcode content must be aligned to the human readable attributes that are printed on the Letter and be appropriate for the service used.</li> <li>The Mailmark 2D code or 4-state barcode must always be located on the same side of the envelope as the Indicia and the Delivery Address block.</li> <li>The Mailmark 2D code or 4-state barcode and clear zone must remain visible at all times.</li> <li>The Mailmark 2D code or 4-state barcode must not be printed over the edge of the envelope flap.</li> </ul>	M M M M M
	E Manifest Handling Specification	Mailings must meet the requirements of the E Manifest Handling System Customer Upload Specification (process and implementation).	M
	Mailmark Barcode Specification	The Mailmark codes must meet the requirements of Mailmark Barcode Specification (2D & 4-State Code and content definition).	M
2D Codes	Code Type	<p>You must use a Data Matrix type ECC200 code complying with the international standard ISO/IEC 16022:2006. Formats 7, 9, or 29 may be used.</p> <div style="display: flex; justify-content: space-around; align-items: center;"> <div style="text-align: center;">  <p><b>Format 7</b> (24 x 24 modules)</p> </div> <div style="text-align: center;">  <p><b>Format 9</b> (32 x 32 modules)</p> </div> <div style="text-align: center;">  <p><b>Format 29</b> (48 x 16 modules)</p> </div> </div>	M
	Data Content	The data content must comply with the C40 encodation scheme (Basic Character set - Uppercase Alphas, Numerals and SPACE only) as described within ISO 16022:2006. Full details of the required Mailmark 2D code content is provided in the EIB Barcode Definition Document.	M
	Size & Shape	<ul style="list-style-type: none"> <li>The Mailmark 2D code must have a module size of 0.5 – 0.7mm</li> <li>Every module must be square.</li> <li>The Mailmark 2D Code must be orientated horizontally or vertically, but must not intentionally be printed with any degree of skew.</li> </ul>	M M M
	Clear Zone	<ul style="list-style-type: none"> <li>No other text, patterning, or graphics shall be printed in an area around the 2D code that is at least 4 times the module size (i.e. at least 2mm when the module size is 0.5mm, and at least 2.8mm when the module size is 0.7mm).</li> <li>The clear zone requirements apply at all times, including when windows envelopes are used and after the Letter is tapped on all four edges, to induce maximum insert movement i.e. The whole of the 2D code and the Delivery Address block together with their required clear zones must be visible at all times.</li> </ul>	M M
	Location	<p>The 2D code must not be printed in the Letter border area (see Figure 9 to Figure 12):</p> <ul style="list-style-type: none"> <li>Landscape - 15mm top, left and right, and 18mm at the bottom;</li> <li>Portrait - 18mm left, 15mm top, right and bottom;</li> <li>The 2D code may encroach into the Indicia area provided sufficient space is left for the indicia and its associated clear zone. (i.e. top right corner (landscape or portrait) in an area 75mm long &amp; 40mm high);</li> <li>The 2D code must not be printed in the tag codemark clear zone (i.e. 60mm up from the bottom right corner of the Letter, and 10mm high x 100mm long);</li> <li>Where the address and Mailmark code are printed onto a label, the Mailmark clear zone (including the clear zone to the edge of the label) must be maintained. The Delivery Address clear zone may be limited to 2mm.</li> </ul>	M M M M M



Category		Specification Requirement	M/R
2D Codes Cont.	Print Quality	<ul style="list-style-type: none"> <li>The 2D code shall be printed in black on a background that is of consistent contrast by design, with a positive contrast for the symbol (dark on a light background).</li> </ul>	M
	Print Quality Cont.	<ul style="list-style-type: none"> <li>The 2D code must be printed to ISO 15415:2011 grades 4(A) or 3(B) when read under white light. Note: A and B are the equivalent ANSI standards understood by American standard users. (A Module size of 0.5mm equates to 6 dots when printed at 300dpi, whilst a module size of 0.7mm equates to 8 dots when printed at 300dpi).</li> <li>No other text, patterning, or graphics shall be printed in the area occupied by the 2D code.</li> <li>Printing or embossing of security backgrounds, if essential, should be faint, of uniform consistency and be on the inside of the envelope.</li> </ul>	M L <sup>21</sup>
4-State Barcode		<p>The 4-State barcode is a barcode that uses 4-State symbology. The data is encoded to produce a barcode that includes bars in 4 possible states - "D" = Descender bar, "A" = Ascender bar, "F" = Full bar, "T" = Track bar (DAFT). Two codes are available:</p> <ul style="list-style-type: none"> <li>Barcode C – Consolidators – 66 bars, and up to 84mm long</li> </ul>  <ul style="list-style-type: none"> <li>Barcode L – High volume Mailers – 78 bars and up to 99mm long.</li> </ul> 	
	Data Content	The code content must be aligned to the human readable attributes that are printed on the Letter, and be appropriate for the product used.	M
	Size & Shape	<ul style="list-style-type: none"> <li>The 4-State barcode must be printed at a pitch of 20-24 bars per 25.4mm.</li> <li>The barcode pitch must be consistent throughout the length of the code.</li> <li>The Ascender and Descender bars are 1.6 to 2.16 mm high, the Track bar is 1.02 to 1.52 mm high, and the bar width is 0.38 to 0.63 mm, with the full bar being 4.22mm to 5.84mm high. The width requirements apply throughout the whole bar. i.e. No part of the bar can be less than 0.38mm wide or greater than 0.63mm wide.</li> <li>The print quality must be consistent throughout the code. i.e. There must be no gaps between printed dots that may be used to print the code.</li> </ul>	M M M M
	Symmetry & Skew	<ul style="list-style-type: none"> <li>The vertical alignment of the code must be consistent. The track element of the bars must be symmetrical about the centre line of the code, plus or minus 10% of the height of the centre line (see Figure 15).</li> <li>The barcode skew must be less than 5° (see Figure 16 &amp; Figure 17).</li> </ul>	M M
	Code Clear Zone	<ul style="list-style-type: none"> <li>A clear zone of 2mm must be maintained on all four sides of the 4-State barcode.</li> <li>The clear zone requirements apply at all times, including when window envelopes are used and after the mail item is tapped on all four edges, to induce maximum insert movement (i.e. the whole of the 4-State barcode and the address block together with their required clear zones must be visible at all times).</li> </ul>	M M
	Location	<p>The 4-State barcode must not be printed in the border area (see Figure 9 to Figure 12):</p> <ul style="list-style-type: none"> <li>Landscape – 15mm top, left and right, and 18mm at the bottom;</li> <li>Portrait – 18mm left, 15mm top, right and bottom;</li> </ul>	M M M
		<ul style="list-style-type: none"> <li>The 4-State barcode may encroach into the Indicia area provided sufficient space is left for the indicia and its associated clear zone. (i.e. top right corner (landscape or portrait) in an area 75mm long &amp; 40mm high);</li> <li>The 4-State barcode must not be printed in the tag codemark clear zone. i.e. 60mm up from the bottom right corner of the Letter, and 10mm high x 100mm long.</li> <li>The 4-State barcode must not be printed over the edge of the envelope flap.</li> <li>Where the address and Mailmark code are printed onto a label, the Mailmark clear zone (including the clear zone to the edge of the label) must be maintained. The Delivery Address clear zone may be limited to 2mm.</li> </ul>	M M M M
Print Quality		<ul style="list-style-type: none"> <li>The 4-State barcode must be printed in a contrast medium, typically black bars on a white background.</li> </ul>	M

<sup>21</sup> The presence of security backgrounds or embossing may limit 4-State barcode reading performance. Such instances are infrequent.

Category		Specification Requirement	M/R
		<ul style="list-style-type: none"> <li>No other text, patterning, or graphics shall be printed or present in the barcode area and its clear zone (i.e. this may be design graphics or Letter substrate characteristics).</li> </ul>	M
4-State Barcode Cont.	Print Quality Cont.	<ul style="list-style-type: none"> <li>A minimum Print Contrast Ratio (PCR) and a minimum Reflective Difference (RD) must be applied. These values are:               <ul style="list-style-type: none"> <li>Minimum PCR is 40%</li> <li>Minimum RD is 30%</li> </ul> </li> </ul>	M
		<ul style="list-style-type: none"> <li>The print quality shall be consistent throughout the bars.</li> </ul>	H <sup>22</sup>
		<ul style="list-style-type: none"> <li>The edges of the 4-State Mailmark barcode should be sharp and clearly defined.</li> </ul>	H <sup>22</sup>
		<ul style="list-style-type: none"> <li>Printing or embossing of security backgrounds, if essential, should be faint, of uniform consistency and be on the inside of the envelope.</li> </ul>	L <sup>21</sup>

## 5. Codemark Clear Zones

These clear zones relate to the typical location of the orange barcodes that are applied to Letters by Royal Mail to facilitate automated Letter processing.

Category	Specification Requirement	M/R
Tag Codemark	This is located 60mm up from the bottom right corner of the Letter, and covers an area 10mm high, and 100mm long (from the right edge of the Letter). This area should be free of any window material, text and graphics (see Figure 9 to Figure 12).	L <sup>23</sup>
Route Codemark	This is in the bottom right corner of the Letter and covers an area 18mm high (from the bottom edge of the Letter), and 130mm long (from the right edge of the Letter). This area should be free of any window material, text and graphics (see Figure 9 to Figure 12).	L <sup>23</sup>

<sup>22</sup> Ink jet 4-State codemarks that consist of individual dots (rather than a complete bar) may be read. However, any reduction in print quality may limit 4-State barcode reading performance.

<sup>23</sup> The printing of the codemark may impair the artwork visuals.

## 6. One Piece and Wrap Letter Mailers

For the purposes of this section, a One-Piece Mailer is defined as- *'A rectangular or square shaped mailpiece made from rectangular or square paper that is folded and sealed. It may be designed to be opened or to enclose an insert. Its unfolded edges are sealed using either inner glue spots or a continuous glue line.'*

This section defines the specific construction characteristics of One-Piece Mailers (including the machineable postcard that is in effect a permanently sealed one-piece mailer). Other physical requirements together with Indicum, addressing and Mailmark requirements remain as standard. The specification is designed to ensure that Royal Mail Letter processing machines can process and read Letters effectively at high speed without the need for manual or other intervention.

Physical Reqs	One-Piece Mailer / Wrap Mailer – standard option	One-Piece Mailer / Wrap Mailer – extended option	Feature One-Piece Mailer	Coupon One-Piece Mailer	Machineable Postcard
Purpose	This option covers the multi-fold mailer, together with designs that provide a one-piece alternative to the traditional envelope.	This option covers the multi-fold mailer, together with designs that provide a one-piece alternative to open or poly-wrapped large letters that are no more than 248mm long.	This mailer is specifically designed to open out easily into a full-page feature that is not damaged by fibre tear because of gluing.	This mailer is specifically designed to provide a pocket in which a small booklet can be inserted.	This mailer is specifically designed to provide a postcard of 2/3 ply. The 3-Ply element provides a reference edge for the mailer, and the varied thickness ensures the items do not stick together.
Inserts	Only Paper inserts are permitted (H <sup>24</sup> )		(M) No Insert is permitted	<ul style="list-style-type: none"> <li>• (M) The booklet must be paper only.</li> <li>• (M) The booklet must rest on the reference edge (the longest edge opposite the Indicia)</li> <li>• (M) The booklet must be affixed to the inside the mailer to prevent movement during processing.</li> <li>• The booklet insert should be no more than 85mm x 130mm in size and the mailer should be no more than 2mm thick (H <sup>25</sup>)</li> </ul>	No Insert is permitted
Shape	(M) Rectangular or Square			(M) Rectangular only	(M) As specified below

<sup>24</sup> Increasing the weight of a paper insert e.g. a booklet is likely to impact and reduce the robustness of the mail piece. Regardless of the insert weight items must be sealed securely to ensure the mailing item can contain all inserts during processing by Royal Mail.

<sup>25</sup> These requirements relate to the designs that have been tested.

<p style="text-align: center;"><b>Multiple Folds</b></p>	<p><b>(M)</b> The long edges of the finished mailpiece must be folds, and the short edges and flap must be sealed.</p>	<p>Maximum 2 folds (<b>L 25</b>)</p>	<p>Folded three times to produce a pocket as follows (<b>L 25</b>) :-          Fold 1 - 70mm from bottom edge.          Fold 2 - 215mm from bottom.          Fold 3 - 360mm from bottom</p>	<p><b>(M)</b> The bottom of the finished mailpiece must have a 3-Ply paper thickness amounts to 45% of the height of the shorter edge of the finished mailpiece, whilst the top amounts to 55% of the height of the shorter edge of the finished mailpiece, (a manufacturing tolerance of plus or minus 2mm is permitted). Two physical design options are available:</p> <ol style="list-style-type: none"> <li>1. -The 3-ply paper must be cut finished so all three layers form a single bottom (reference) edge. i.e. the edge consists of 3 layers of paper and 2 layers of adhesive. The finished cut edge must look as if it is a single edge. (See Figure 20)</li> <li>2. The paper must be folded such that the first fold creates an internal flap. The second fold must form another flap that covers the internal flap and ends 1mm short of the bottom</li> </ol>
----------------------------------------------------------	------------------------------------------------------------------------------------------------------------------------	--------------------------------------	---------------------------------------------------------------------------------------------------------------------------------------------------------------------------------------------------------	--------------------------------------------------------------------------------------------------------------------------------------------------------------------------------------------------------------------------------------------------------------------------------------------------------------------------------------------------------------------------------------------------------------------------------------------------------------------------------------------------------------------------------------------------------------------------------------------------------------------------------------------------------------------------------------------------------------------------------------------------------------------------------------------------------------------------------------------------------------------------------

Physical Reqs	One-Piece Mailer / Wrap Mailer – standard option	One-Piece Mailer / Wrap Mailer – extended option	Feature One-Piece Mailer	Coupon One-Piece Mailer	Machineable Postcard
					(reference) edge. (See Figure 21)
<b>Reference Edge</b> <sup>26</sup>	<ul style="list-style-type: none"> <li>• (M) The reference must be a folded edge on the mailpiece</li> <li>• (M) For landscape the folded reference edge is the edge beneath the address.</li> <li>• (M) For portrait items the reference edge is the longest left edge.</li> <li>• (M) For square mailers, the reference edge is the edge beneath the address.</li> </ul>	<ul style="list-style-type: none"> <li>• (M) The reference must be a folded edge on the mailpiece</li> <li>• (M) For landscape the folded reference edge is the edge beneath the address.</li> <li>• (M) For portrait items the reference edge is the longest left edge.</li> </ul>	<ul style="list-style-type: none"> <li>• (M) The reference must be a folded edge on the mailpiece</li> <li>• (M) For landscape the folded reference edge is the edge beneath the address.</li> <li>• (M) For portrait items the reference edge is the longest left edge.</li> <li>• (M) For square mailers, the reference edge is the edge beneath the address.</li> </ul>	<ul style="list-style-type: none"> <li>• (M) Must be a folded edge.</li> <li>• (M) For landscape this is the longest edge beneath the address.</li> <li>• (M) For portrait items this is the longest left edge.</li> </ul>	
<b>Mailer Dimensions</b>	(M) Minimum and maximum mailpiece dimensions.	(M) Minimum mailpiece dimensions & maximum – 165mm high x 248mm long	(M) Minimum and maximum mailpiece dimensions.	165mm plus or minus 5mm x 145mm plus or minus 5mm. (L <sup>25</sup> )	(M) Minimum and maximum mailpiece dimensions.
<b>Mailer Thickness</b>	(M) Minimum and maximum mailpiece thickness	(M) Minimum mailpiece thickness & maximum 3mm	(M) Minimum and maximum mailpiece thickness	(H <sup>27</sup> ) 2mm including insert.	(M) Minimum and maximum mailpiece thickness.
<b>Mailer Max weight</b>	(M) Minimum and maximum mailpiece weight.	(M) Minimum mailpiece weight & maximum 70g	(M) Minimum and maximum mailpiece weight.	(L <sup>25</sup> ) No more than 20g	(M) Minimum & maximum mailpiece weight
<b>Paper Weight</b>	(M) Minimum 100gsm		(M) 150gsm - 190gsm	(M) Minimum 115gsm	(M) 120gsm – 150gsm (150gsm recommended)
<b>Paper Thickness</b>	Not applicable		0.13mm - 0.175mm (L <sup>25</sup> )	Not applicable	(M) 2-Ply element minimum 0.18mm (M) 3-Ply element minimum 0.27mm

<sup>26</sup> The reference edge is a fold on a particular edge of the Letter, which enables it to be processed through the machines efficiently.

<sup>27</sup> Inconsistent thickness causes mechanical handling issues.

Physical Reqs	One-Piece Mailer / Wrap Mailer – standard option	One-Piece Mailer / Wrap Mailer – extended option	Feature One-Piece Mailer	Coupon One-Piece Mailer	Machineable Postcard
Flaps	<ul style="list-style-type: none"> <li>Flap should run parallel to the reference edge and may be on the front or back of the mailer. (L<sup>25</sup>)</li> <li>The minimum height for a flap 25mm. (L<sup>25</sup>)</li> <li>The maximum height for a flap depends on the mailpiece size but must be less than 40mm from the bottom of the mailpiece. (L<sup>25</sup>)</li> </ul>		Not applicable	Fold 3 forms a sealing flap 35mm deep. (L <sup>25</sup> )	Not applicable
Sealing	<u>With Inserts</u> (M) All unfolded sides (including the flap) must be glued with a <b>continuous seal</b> . <u>No Inserts</u> (M) All unfolded sides must be glued using a spot seal or a continuous seal.	(M) All unfolded sides (including the flap) must be glued with a <b>continuous seal</b> .	(M) All unfolded sides must be glued using a <b>spot or continuous seal</b>	(M) All unfolded sides must be glued with a <b>continuous seal</b> .	
Security / Presentation	<ul style="list-style-type: none"> <li>(M) Items must be securely sealed when presented to Royal Mail</li> <li>(M) The mailer must be flat and must not be curled.</li> <li>(M) Mailpieces must not be stuck or caught together.</li> </ul>				
Glue	<ul style="list-style-type: none"> <li>(M) The glue must not be brittle or easily broken.</li> <li>(M) The glue must not seep to the outside of the mailpiece.</li> <li>(M) The cure time for the glue must be sufficient to ensure that it has fully cured prior to being presented to Royal Mail.</li> </ul>				
Peel Adhesion	(M) The peel adhesion strength of glue must be a minimum of 0.4N or paper fibres must be seen to tear if the seal is peeled apart.	<ul style="list-style-type: none"> <li>(M) The peel adhesion strength of glue must be a minimum of 0.2N on the sides.</li> <li>(M) The peel adhesion strength of glue must be a minimum 0.25N on the long edge.</li> </ul>	<ul style="list-style-type: none"> <li>(M) The peel adhesion strength of glue used for the side seals must be a minimum of 0.25N or paper fibres must be seen to tear if the seal is peeled apart.</li> <li>(M) The peel adhesion strength of the flap must be minimum 0.2N or paper fibres must be seen to tear if the seal is peeled apart.</li> </ul>	(M) The peel adhesion strength of glue must be a minimum of 0.4N or paper fibres must be seen to tear if the seal is peeled apart.	
Glue Thickness	No more than 80 microns thick (H <sup>28</sup> )				

<sup>28</sup> Welds greater than this thickness may cause mechanical handling issues.

Physical Reqs	One-Piece Mailer / Wrap Mailer – standard option	One-Piece Mailer / Wrap Mailer – extended option	Feature One-Piece Mailer	Coupon One-Piece Mailer	Machineable Postcard
Spot Gluing	<ul style="list-style-type: none"> <li>• Glue spots may be circular or elliptical. (H 25)</li> <li>• Distance between two closest edges of glue spots should be no more than 10mm (H 25)</li> <li>• Size of spots should be at least 5mm in diameter / length. (H 25)</li> <li>• Maximum distance from edge of mailpiece should be 5mm, plus or minus 2mm (H 25)</li> </ul> (See Figure 22)	(M) This is not permitted	<ul style="list-style-type: none"> <li>• Glue spots may be circular or elliptical.</li> <li>• Side spots should be at least 11mm in diameter and must be no more than 25mm apart. (H 25)</li> <li>• Long edge spots be at least 15mm in diameter / length and should be no more than 45mm apart. (H 25)</li> <li>• Maximum distance from edge of mailpiece should be 5mm, plus or minus 2mm (H 25)</li> </ul> (See Figure 24)	Not applicable	
Continuous Gluing	A minimum 4mm wide sealed to within 3mm of the edge (H 25) (See Figure 23)		Not applicable	<ul style="list-style-type: none"> <li>• Continuous 10mm band of adhesive to the side edges of the mailer. (H 25)</li> <li>• Long edge of flap sealed with 6mm-9mm wide line of adhesive or 2 lines of 2mm-3mm wide adhesive that are 2mm-3mm apart. (H 25)</li> <li>• (M) The adhesive must be no more than 5mm from the edge of the flap.</li> <li>• The sides of the flap should be sealed to the edge of the mailpiece with 6mm-9mm wide line of adhesive or 2 lines of 2mm-3mm wide adhesive that are 2mm-3mm apart. (H 25)</li> </ul> (See Figure 18 & Figure 19)	(M) A permanent and continuous adhesive seal of 15mm width to the side edges of the mailer is required on both open sides of the mailpiece and on the internal flap.

Physical Reqs	One-Piece Mailer / Wrap Mailer – standard option	One-Piece Mailer / Wrap Mailer – extended option	Feature One-Piece Mailer	Coupon One-Piece Mailer	Machineable Postcard
Finish	<ul style="list-style-type: none"> <li>Matt finish is preferred. (H <sup>29</sup>)</li> <li>Digitally Printed Mail – See Note below</li> </ul>				Finish – Matt or Silk (Matt preferred) (H <sup>29</sup> )
Clear Zone inside the mailpiece	10mm clear zone around the inside perimeter clear of print to ensure that the adhesive properties of the glue are not impaired. (L <sup>25</sup> )	Not applicable			

### Note – Digitally Printed Mail

When digital printing is used for mail, the pigment may rub off, transfer to adjacent surfaces (inserts and the envelope), crack, and become marked both during the manual and automated handling process.

The application of an ultra violet (UV) cured varnish has been found to reduce the wear to digitally printed mail items. This provides a protective coating over the pigment. It should only be applied to the non-address side of the mailpiece as the characteristics the varnish may make the mail unmachineable if applied to both sides <sup>30</sup>.

The pressure exerted on the mailpiece during automated processing may cause colour offset on digitally printed items. Therefore, it is recommended that there should be no off-set of print or colour transfer when the item is exposed to a pressure of 3.43kPa (35g per cm<sup>2</sup>). This equates to a weight of 8.5kg spread over the surface of a DL envelope, and 13.5kg for C5 envelopes.

<sup>29</sup> Silk and gloss finished mailpiece are more likely to stick together (i.e. higher double fed mailpieces and missorts).

<sup>30</sup> They may have 'window-like characteristics' that reduce mechanical handling capability, increase static cling, and compromise codemark printing



## 7. Perforated Letter Mailers

For the purposes of this section, a Perforated Letter Mailer is defined as: *'A Letter that is designed to be wholly or partly opened by tearing off a perforated strip.'*

This section defines the specific construction characteristics of Perforated Letter Mailers. These include roulette and zip tie designs, together with the pressure seal mailer. Other physical requirements together with Indicum, addressing and Mailmark requirements remain as standard. The Mailmark specification is designed to ensure that Royal Mail Letter processing machines can process and read Letters effectively at high speed, without the need for manual or other intervention.

### 7.1 Roulette Perforations

Category		Specification Requirement	M/R
Roulette Perforations	Definition	These perforations consist of a line of cuts (holes) and paper bridges in the Letter. Access to the Letter content is gained by tearing the Letter along the line of perforations. 	
	Orientation	The mailpiece must be in either landscape or portrait orientation (but not square).	H
	Design	<ul style="list-style-type: none"> <li>The perforations must be located on both 'short' sides of the mailpiece, and on one of the long sides of the mailpiece. i.e. only 3 sides may be perforated.</li> </ul>	H
		<ul style="list-style-type: none"> <li>The perforations must be inset from the edge of the mailpiece by 12mm, plus or minus 1mm.</li> </ul>	H
		<ul style="list-style-type: none"> <li>The 'short' side perforations must extend to each edge of the envelope.</li> </ul>	H
		<ul style="list-style-type: none"> <li>The 'long' side perforation must not extend beyond the 'short' side perforations.</li> </ul>	H
		<ul style="list-style-type: none"> <li>The indicia must not be printed over the perforations, but the Indicia clear zone may extend into the perforated border.</li> </ul>	H
	<ul style="list-style-type: none"> <li>No other colour should be visible through the perforations that are in the Tag and Route codemark Clear Zones.</li> </ul>	H	
	The above requirements are illustrated in Figure 26 and Figure 27.	H	
Paper Weight	At least 100gsm.	H	
Cuts & Bridges	<ul style="list-style-type: none"> <li>The perforations must be die cut into the mailpiece.</li> </ul>	H	
	<ul style="list-style-type: none"> <li>The cut of the 'short' side perforations must be set at 1.3mm – 2mm, with a bridge of at least 0.8mm (see Figure 28).</li> </ul>	H	
	<ul style="list-style-type: none"> <li>The cut of the long side perforation must be set at 0.5mm – 1.4mm, with a bridge of at least 0.4mm (see Figure 28).</li> </ul>	H	
	<ul style="list-style-type: none"> <li>The cuts must be rectangular in shape and have a width of no more than 0.1mm.</li> </ul>	H	
	<ul style="list-style-type: none"> <li>Each cut must be of uniform size and each bridge must be of uniform size.</li> </ul>	H	
Sealing	<ul style="list-style-type: none"> <li>The perforated edges must be securely sealed all round from the perforation to the letter edges.</li> </ul>	H	
	<ul style="list-style-type: none"> <li>Adhesives used must be dry and must not leak onto the open surface of the Letter.</li> </ul>	H	
	<ul style="list-style-type: none"> <li>The glue must not run out onto the outside of the Letter or produce protruding mounds on the Letter.</li> </ul>	H	
	<ul style="list-style-type: none"> <li>Letters must not be stuck or caught together.</li> </ul>	H	
	<ul style="list-style-type: none"> <li>The glue must be fully cured prior to presentation of the mailing to Royal Mail.</li> </ul>	H	
	<ul style="list-style-type: none"> <li>The peak peel adhesion strength of the glue must be at least 4.5N, and fibre tear must be exhibited on separation.</li> </ul>	H	

## 7.2 Zip Tie Perforations

Category	Specification Requirement	M/R
Zip Tie Perforations	<p>Definition</p> <p>These perforations consist of 2 lines of parallel cuts (holes) and paper bridges in the Letter that form a perforated strip. Access to the Letter content is gained by tearing the strip along the lines of perforations in a particular direction.</p> 	
	<p>Orientation</p> <p>The mailpiece must be in either landscape or portrait orientation (square letters are not acceptable).</p>	H
	<p>Design</p> <ul style="list-style-type: none"> <li>The zip tie must always be placed on the back of the mailpiece.</li> <li>The zip tie may be positioned either horizontally or vertically, but the 'Tear' direction of the tie is dependent upon the orientation of the mailpiece. (This is defined in Figure 29 and Figure 30; the orientation and 'Tear' directional requirements relative to position of the Indicia on the front of the Letter being illustrated).</li> <li>The zip tie must be located on a flap that is at least 40mm wide (see Figure 31).</li> <li>The zip tie must be positioned at least 9mm from the edge of the flap (see Figure 31).</li> </ul>	H H H H
	<p>Paper Weight</p> <p>At least 150 gsm.</p>	H
	<p>Cuts &amp; Bridges</p> <ul style="list-style-type: none"> <li>Only one zip tie is permitted on each mailpiece.</li> <li>The zip tie must be die cut into the mailpiece.</li> <li>The dimensional requirements for the cut of the zip tie are provided in Figure 32.</li> <li>The cuts must be rectangular and have a width of no more than 0.1mm.</li> <li>All cuts and bridges must be of uniform size.</li> </ul>	H H H H H
	<p>Sealing</p> <ul style="list-style-type: none"> <li>Envelopes must be securely sealed on the front, back and all edges.</li> <li>The perforated edges must be securely sealed all round from the perforation to the letter edges.</li> <li>The glue must not run out onto the outside of the Letter or produce protruding mounds on the Letter.</li> <li>Adhesives used must be dry and must not leak onto the open surface of the Letter.</li> <li>Letters must not be stuck or caught together.</li> <li>The glue must be fully cured prior to presentation of the mailing to Royal Mail.</li> <li>The sealing adhesive(s) must be no more than 80 microns thick.</li> <li>The peak peel adhesion strength of the glue must be at least 4.5N, and fibre tear must be exhibited on separation.</li> </ul>	H H H H H H H

### 7.3 Pressure Seal Perforations

Category		Specification Requirement	M/R
Pressure Seal	Definition	This form of Letter has roulette perforations through all layers in a perforated strip on the short sides of the Letter, and a roulette perforation tear off strip on the back. i.e. The short side perforations go through the 3 layers on DL size Letters and through the 2 layers on C5 size Letters. It is produced from a single sheet of paper and designed to be opened by removing the short edge perforated strips first; then removing the tear off strip on the reverse of the mailer to access the content.	
	Orientation	The Letter must be in either landscape or portrait orientation (square letters are not acceptable).	H
Pressure Seal Envelope Cont.	Design	<ul style="list-style-type: none"> <li>The perforations must be located on both 'short' sides of the Letter (i.e. the perforated strip), with the roulette tear strip being on the back of the Letter.</li> </ul>	H
		<ul style="list-style-type: none"> <li>The long edge furthest from the indicia (bottom side on Landscape mail and left side on portrait mail) must be a fold.</li> </ul>	H
		<ul style="list-style-type: none"> <li>Additional inserts are not permitted.</li> </ul>	H
		<ul style="list-style-type: none"> <li>The perforated strip must be inset from the sides of the Letter by 12mm, plus or minus 1mm (see Figure 33 and Figure 34).</li> </ul>	H
		<ul style="list-style-type: none"> <li>The perforated strip must extend to each edge of the envelope (see Figure 33 and Figure 34).</li> </ul>	H
		<ul style="list-style-type: none"> <li>The indicia must not be printed over the perforations, but the Indicia clear zone may extend into the perforated border.</li> </ul>	H
		<ul style="list-style-type: none"> <li>Only one roulette tear strip is permitted on each Letter.</li> </ul>	H
		<ul style="list-style-type: none"> <li>The roulette tear strip must be at least 10mm from the long edge of the Letter, and must be at least 10mm wide.</li> </ul>	H
	Paper Weight	<ul style="list-style-type: none"> <li>3-ply DL design - at least 100gsm, 2-ply C5 design - at least 150gsm.</li> </ul>	H
	Short Edge Roulette Perforations	<ul style="list-style-type: none"> <li>The perforations must be die cut into the Letter.</li> </ul>	H
<ul style="list-style-type: none"> <li>The cut of the 'short' side perforations must be set at 1.3 – 2mm, with a bridge of at least 0.8mm (see Figure 28).</li> <li>The cuts must be rectangular and have a width of no more than 0.1mm.</li> <li>Each cut must be of uniform size and each bridge must be of uniform size.</li> </ul>		H	
Long Edge Roulette Tear Off Strip	<ul style="list-style-type: none"> <li>The perforations must be die cut into the Letter.</li> </ul>	H	
	<ul style="list-style-type: none"> <li>The cut of the 'Tear Strip' perforations must up to 3.3mm, with a bridge of at least 0.6 mm (see Figure 28).</li> <li>The cuts must be rectangular and have a width of no more than 0.1mm.</li> <li>Each cut must be of uniform size and each bridge must be of uniform size.</li> </ul>	H	
Sealing	<ul style="list-style-type: none"> <li>Envelopes must be securely sealed on the front, back and all edges.</li> </ul>	H	
	<ul style="list-style-type: none"> <li>The perforated edges must be securely sealed all round from the perforation to the letter edges.</li> </ul>	H	
	<ul style="list-style-type: none"> <li>Where the roulette tear strip may extend into 'short' side Perforations, it must be securely sealed<sup>31</sup>, and the sealed edge between the roulette tear strip and the edge of the Letter must be securely sealed along its entire length (including the part that extends into the perforated area).</li> </ul>	H	
	<ul style="list-style-type: none"> <li>The glue must not run out onto the outside of the Letter or produce protruding mounds on the Letter.</li> </ul>	H	
	<ul style="list-style-type: none"> <li>Adhesives used must be dry and must not leak onto the open surface of the Letter.</li> </ul>	H	
	<ul style="list-style-type: none"> <li>Letters must not be stuck or caught together.</li> </ul>	H	
	<ul style="list-style-type: none"> <li>The glue must be fully cured prior to presentation of the mailing to Royal Mail.</li> </ul>	H	
	<ul style="list-style-type: none"> <li>The sealing adhesive(s) must be no more than 80 microns thick.</li> </ul>	H	
	<ul style="list-style-type: none"> <li>The peak peel adhesion strength of the glue must be at least 4.5N, and fibre tear must be exhibited on separation.</li> </ul>	H	

<sup>31</sup> This ensures that the Perforated Strips are totally sealed long their length.

# Mailmark Letters - Figures

## 1. Physical Requirement Figures

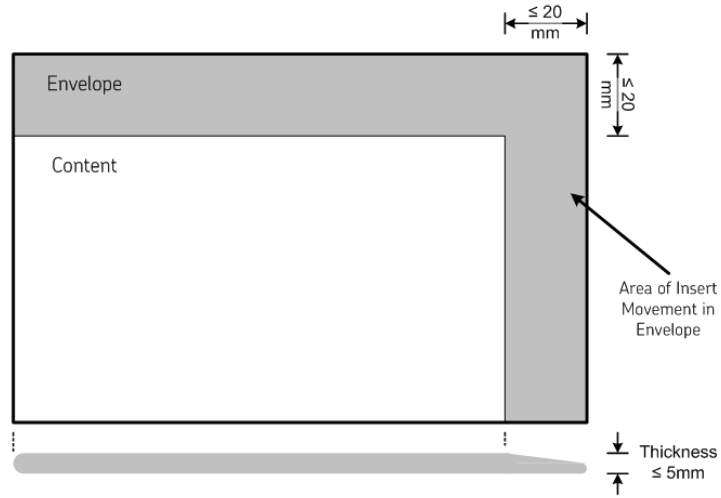

Figure 1 - Letter Inserts (Not to Scale)

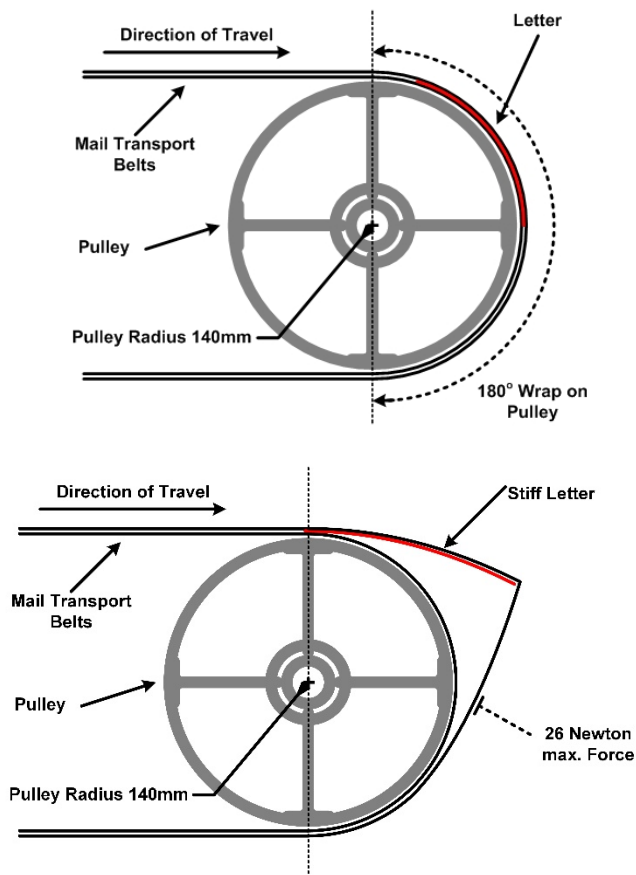

Figure 2 - Letter Flexibility (Not to Scale)

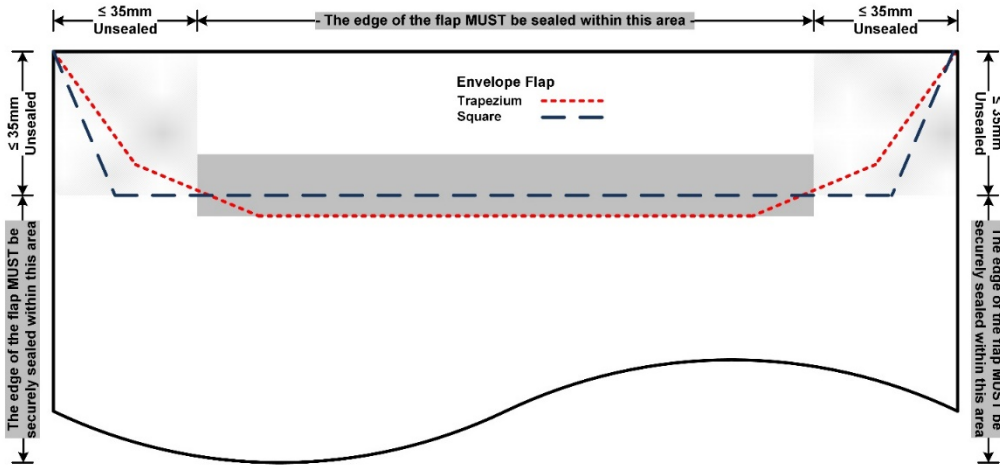

Figure 3 – Letter Sealing – Trayed (Not to Scale)

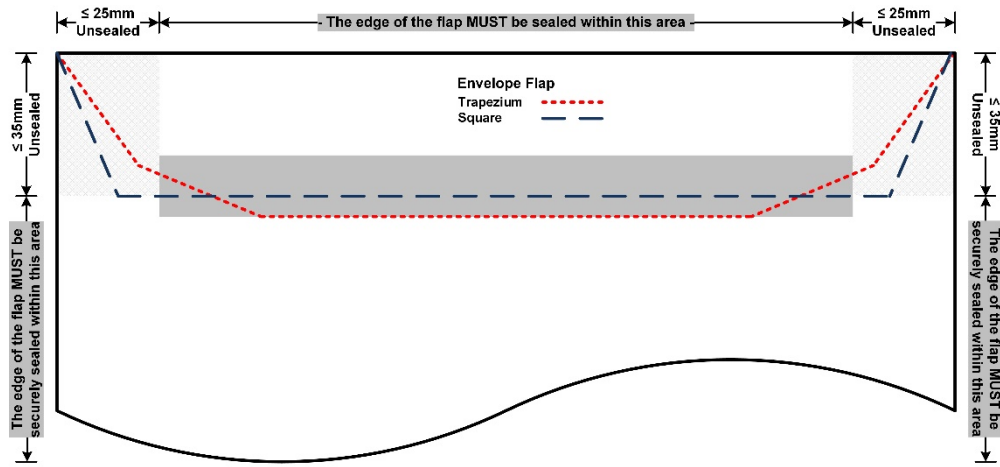

Figure 4 – Letter Sealing – Untrayed (Not to Scale)

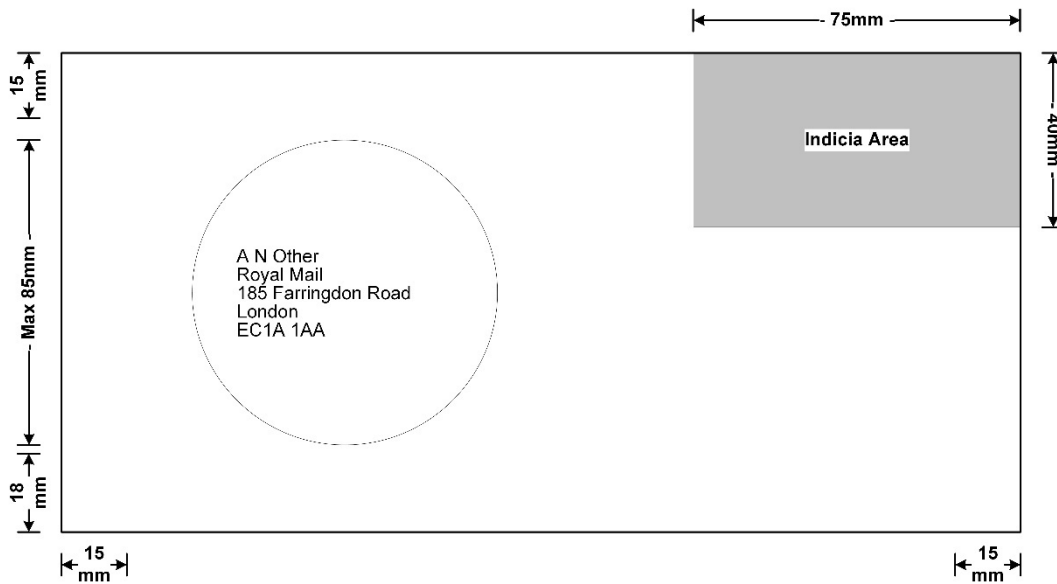

Figure 5 – Circular Window (Not to Scale)

## 2. Indicia Figures

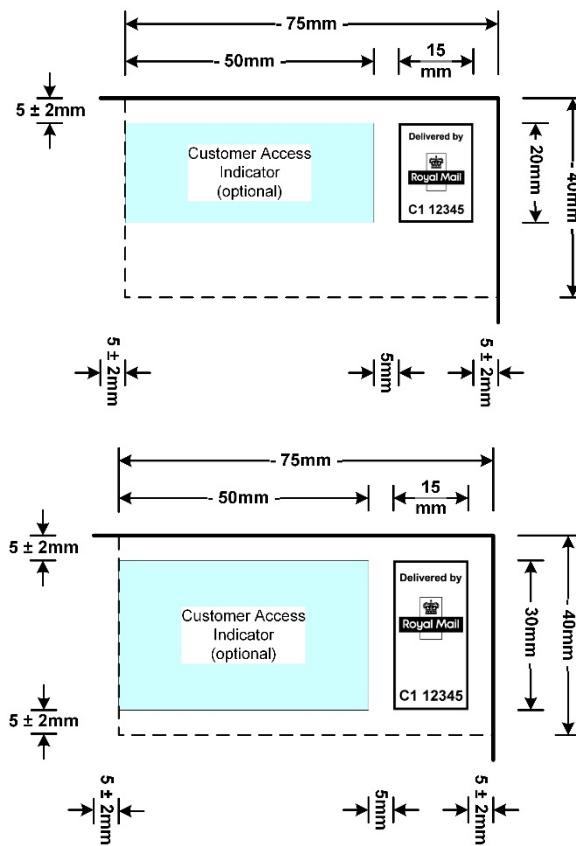

Figure 6 – Letter Indicia Location & Clear Zones

## 3. Addressing Figures

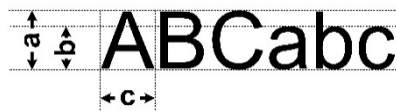

Figure 7 – Letter Font Ratio

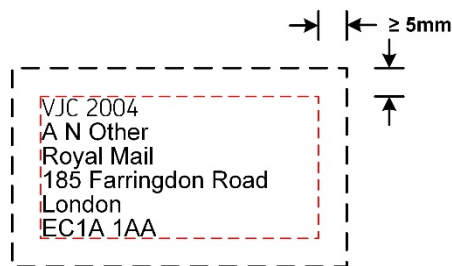

Figure 8 – Delivery Address Block (Not to Scale)

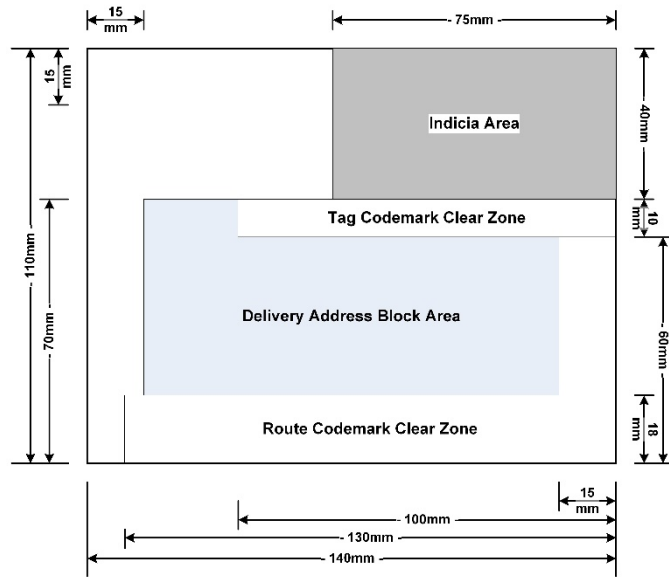

Figure 9 - Letter Clear Zones - Minimum Size (Not to Scale)

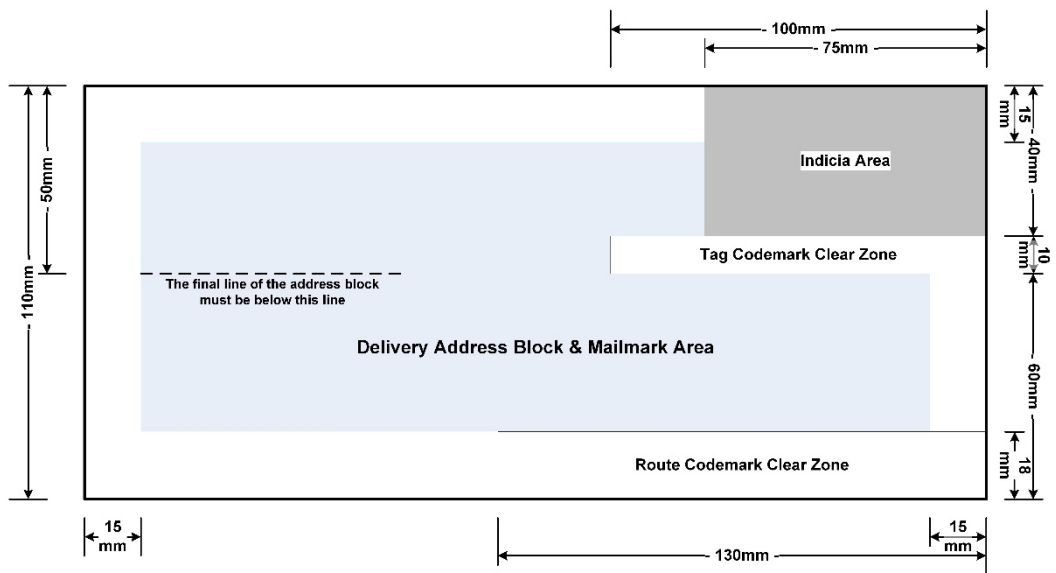

Figure 10 - Letter Clear Zones - DL Envelope (Not to Scale)

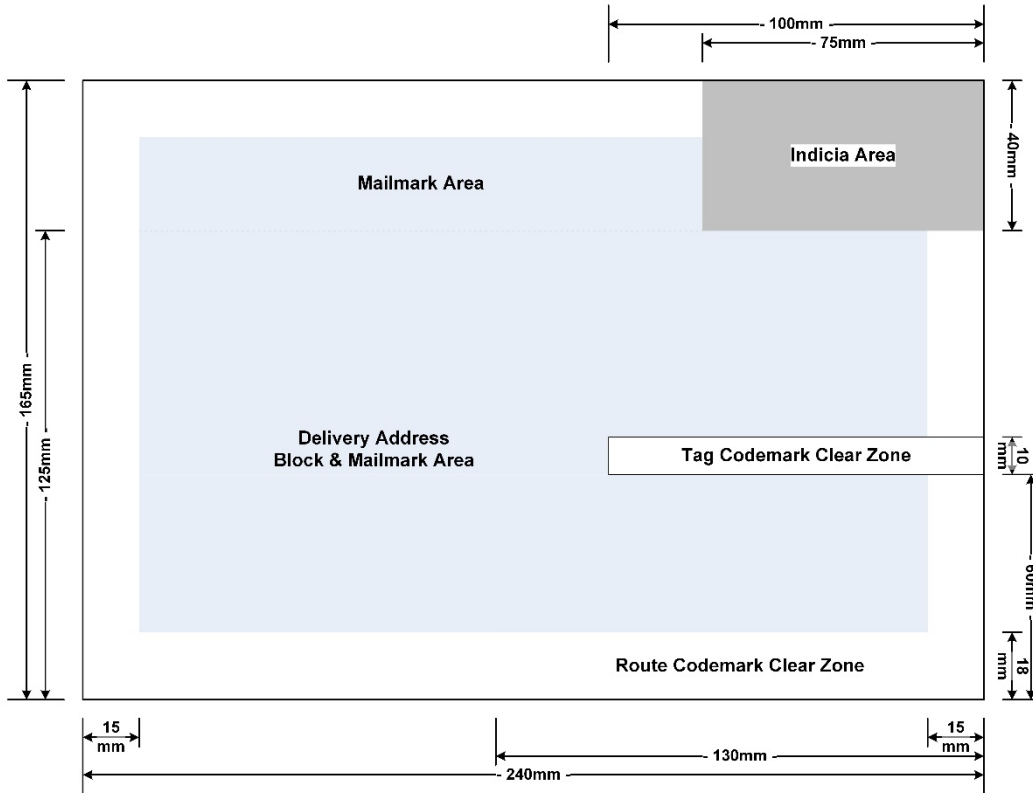

Figure 11 - Letter Clear Zones - Maximum Landscape (Not to Scale)

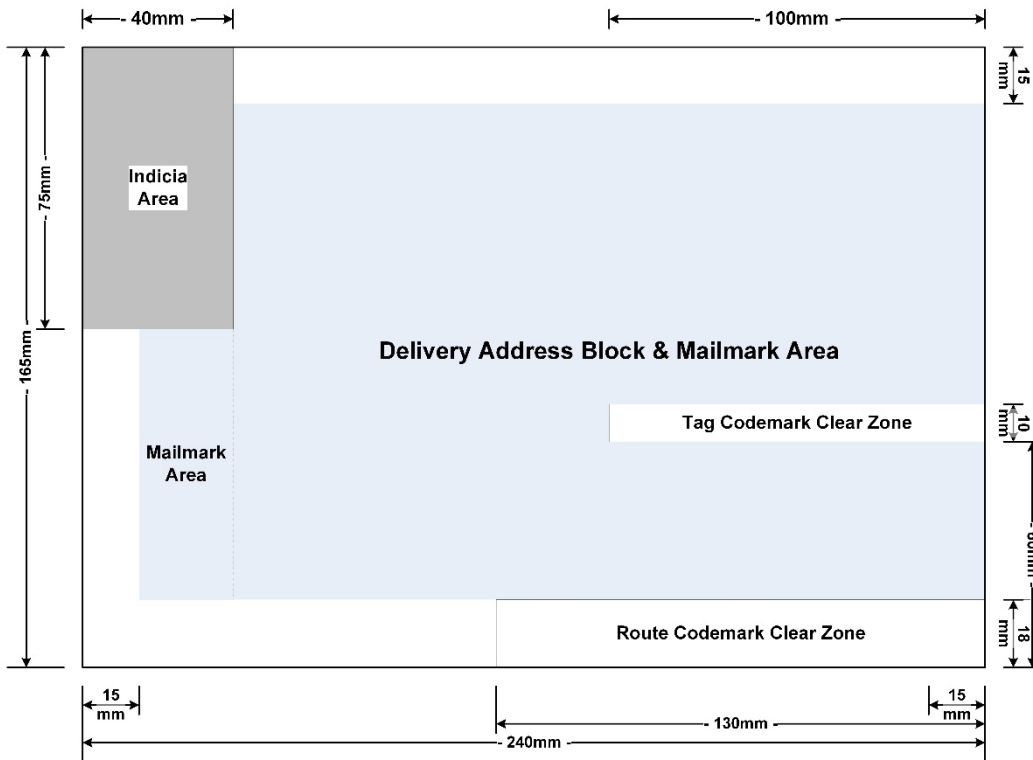

Figure 12 - Letter Clear Zones - Maximum Portrait (Not to Scale)



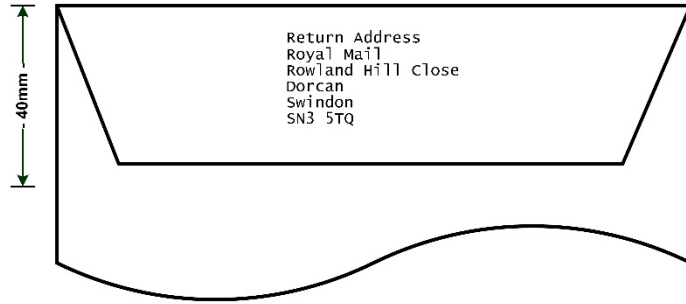

Figure 13 – Letter Return Address Preferred – Back (Not to Scale)

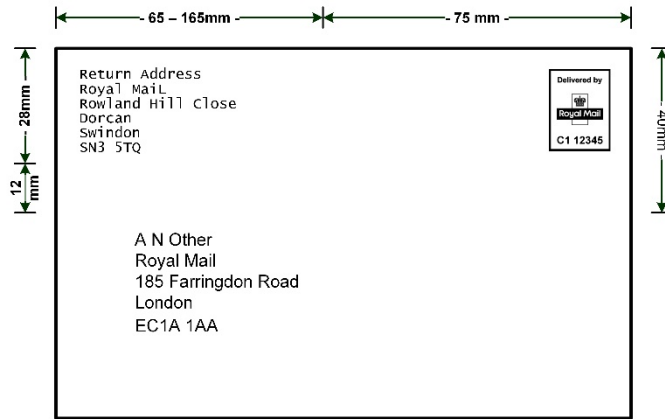

Figure 14 – Letter Return Address – Front Landscape Example (Not to Scale)

#### 4. Mailmark Figures

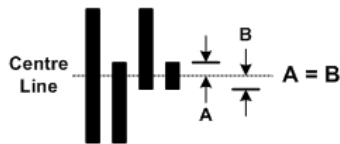

Figure 15 – 4-State Mailmark Barcode Symmetry



Figure 16 – 4-State Mailmark Barcode Bar Skew Y (Not to Scale)



Figure 17 – 4-State Mailmark Barcode Code Skew Z (Not to Scale)

5. One Piece & Wrap Letter Mailer Figures

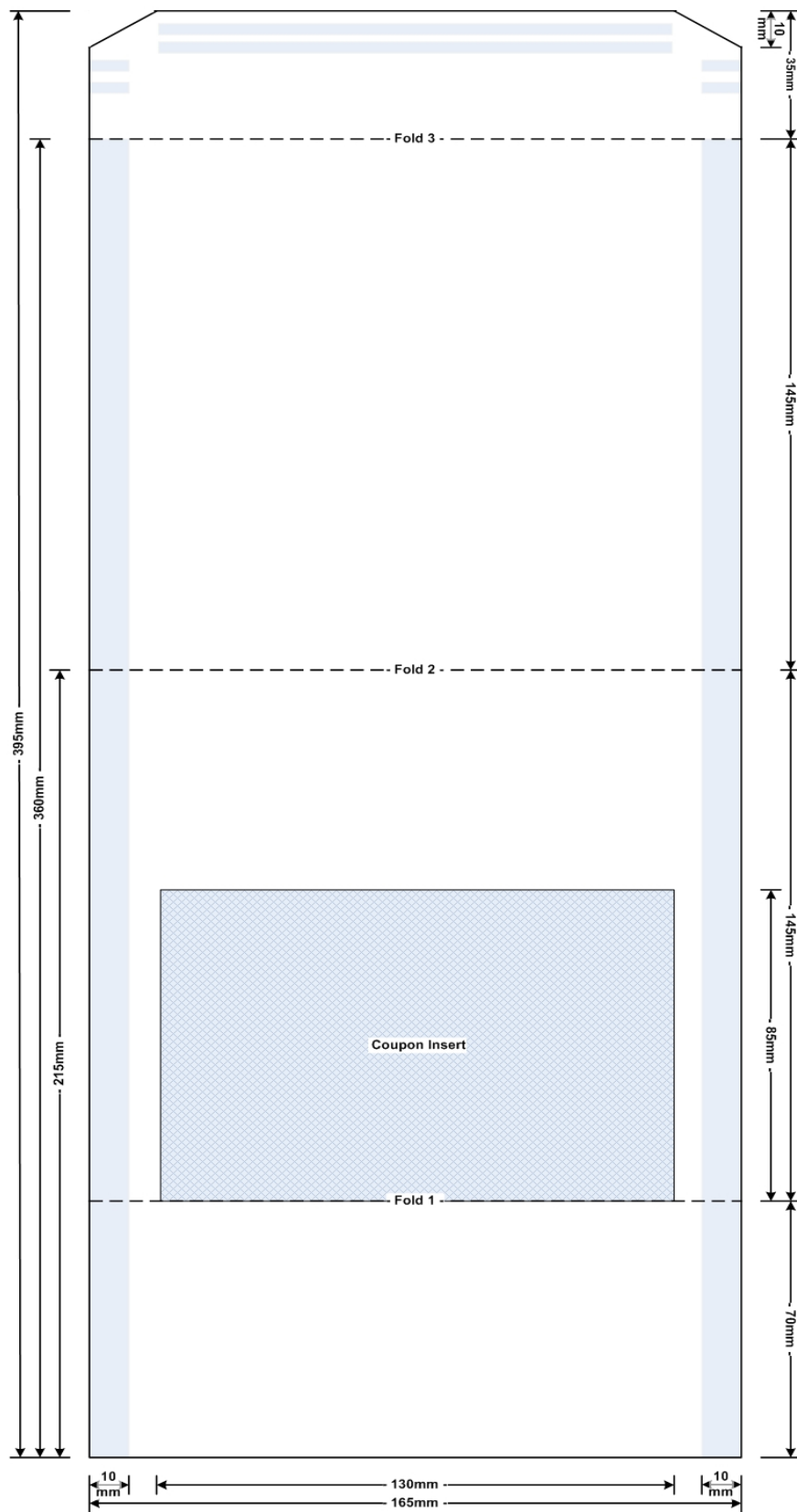

Figure 18 - Coupon One-Piece Letter Mailer - Dimensions (Not to Scale)

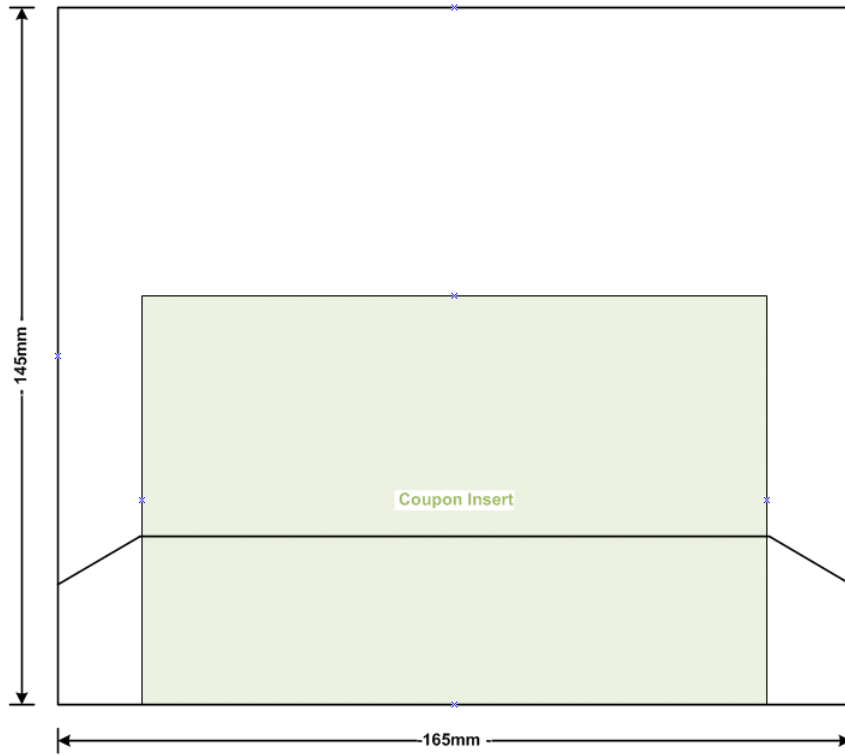

Figure 19 – Coupon One-Piece Letter Mailer – Finished (Not to Scale)

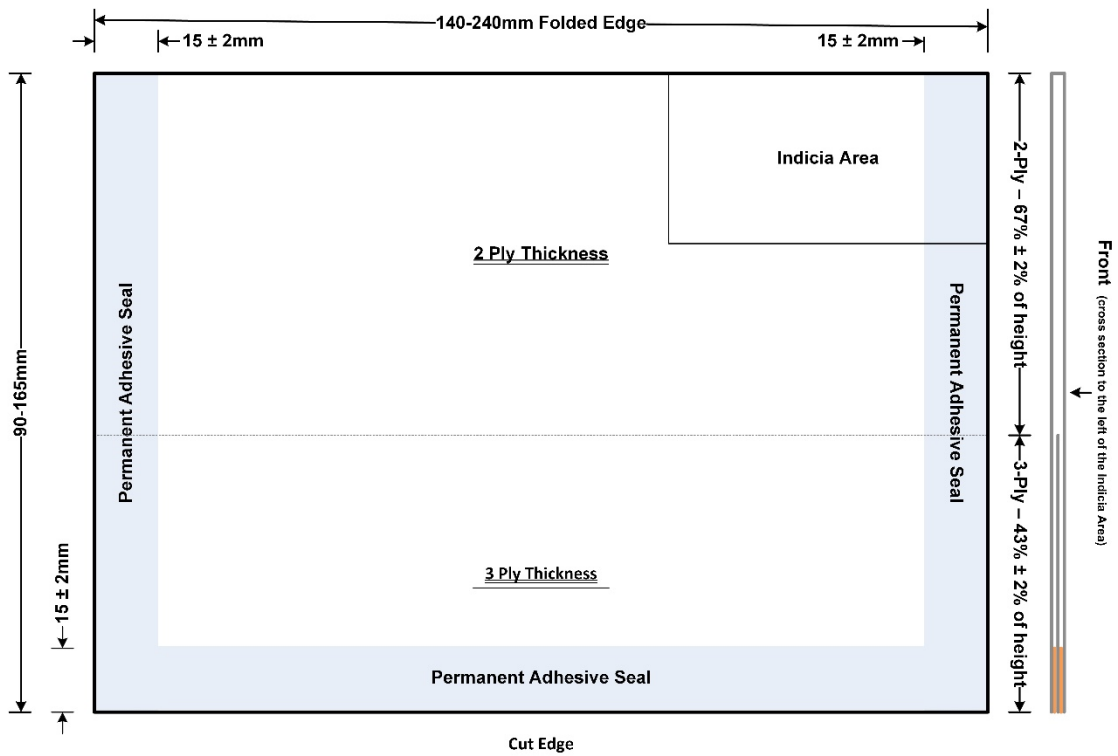

Figure 20 – Machineable Postcard Option 1 (Not to Scale)

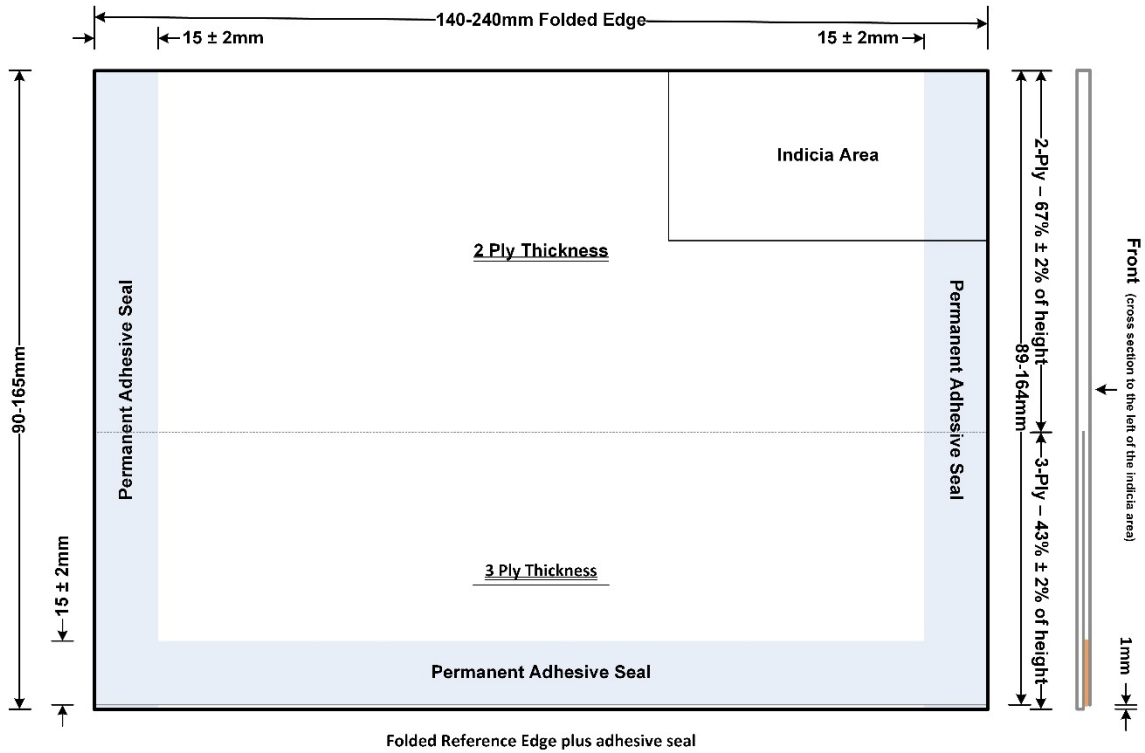

Figure 21 – Machineable Postcard Option 1 (Not to Scale)

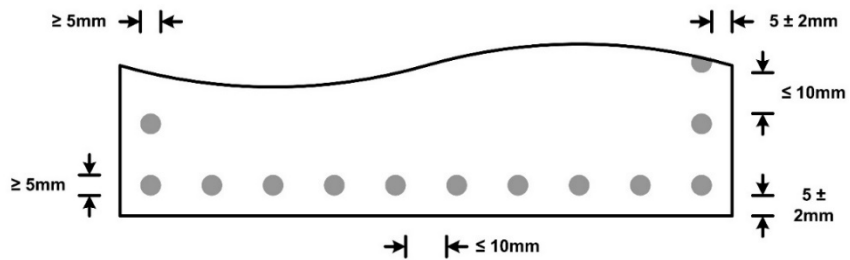

Figure 22 – Standard One-Piece Letter Mailer – Spot Weld Requirements (Not to Scale)

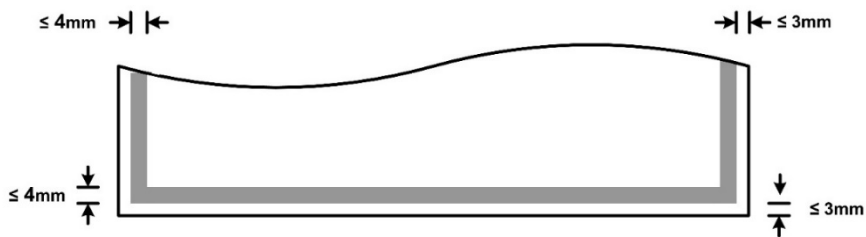

Figure 23 – Standard One-Piece Letter Mailer – Glue Line Requirements (Not to Scale)

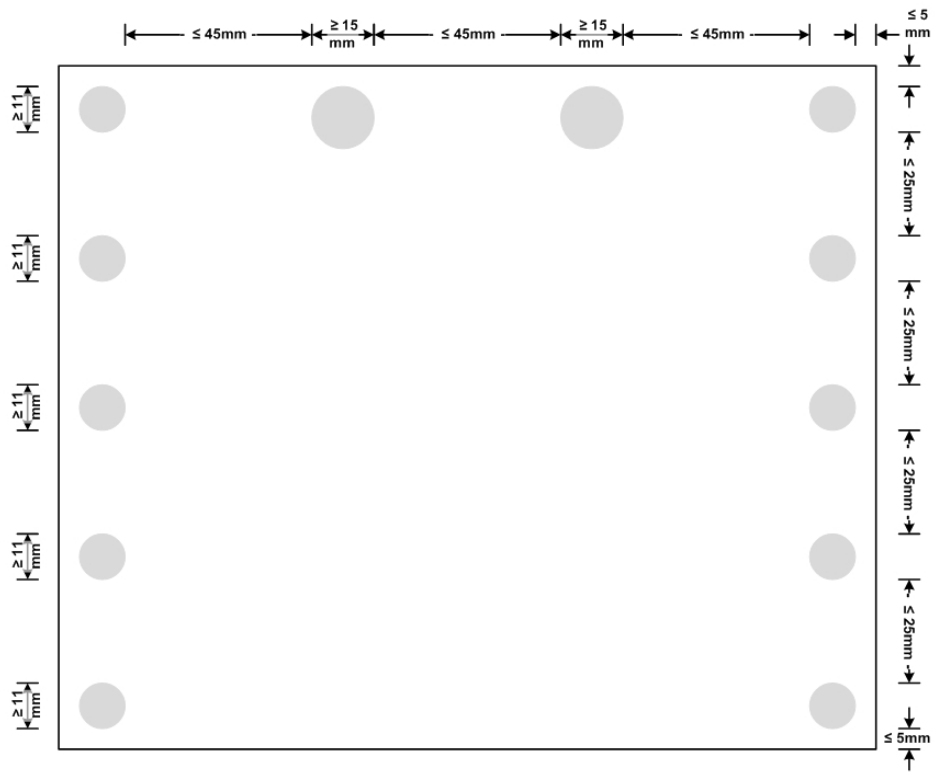

Figure 2421 - Feature Letter Mailer (Not to Scale)



Figure 25 - Standard One-Piece Letter Mailer - Internal Perimeter Clear Zone (Not to Scale)

6. Perforated Letter Mailers Figures

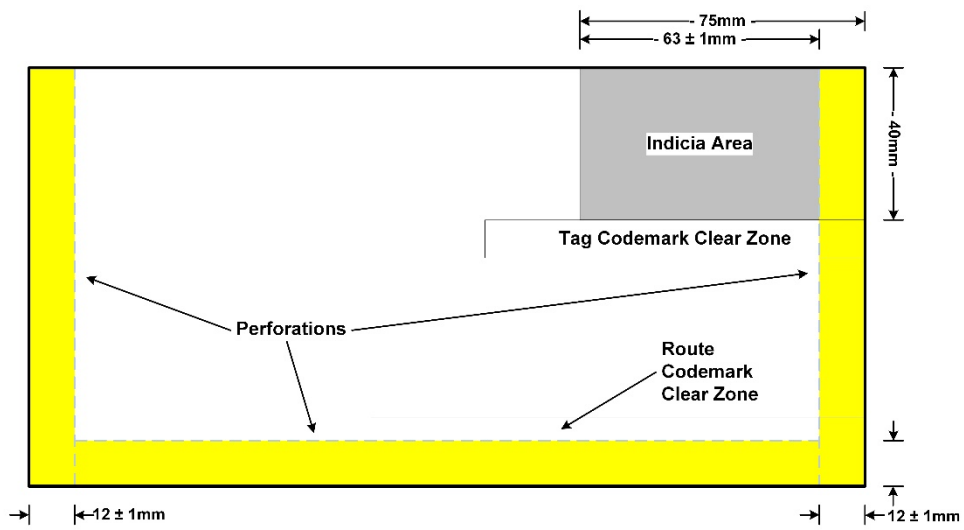

Figure 26 - Roulette Perforation Landscape Letter - Bottom Perforation (Not to Scale)

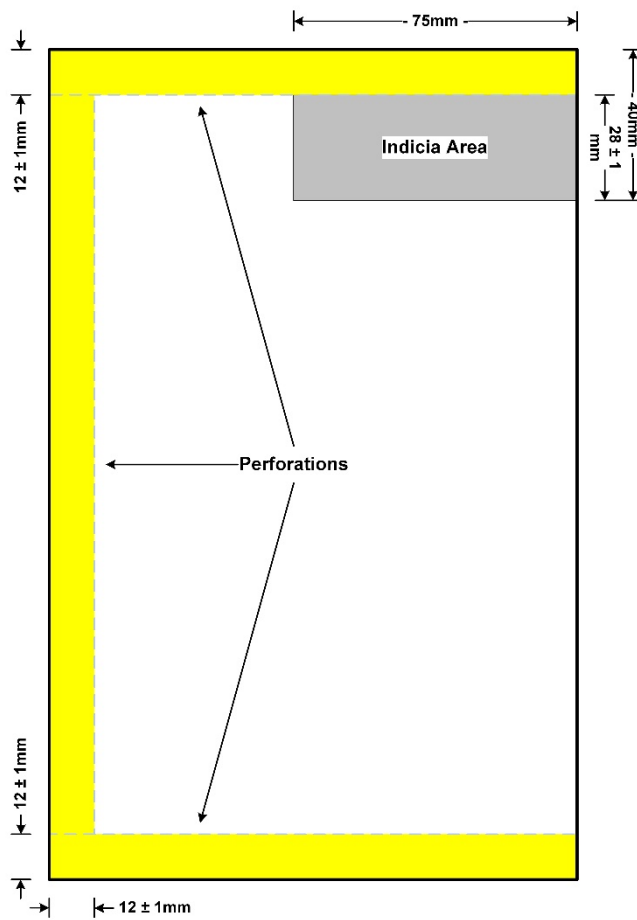

Figure 27 - Roulette Perforation Portrait Letter - Left Perforation (Not to Scale)

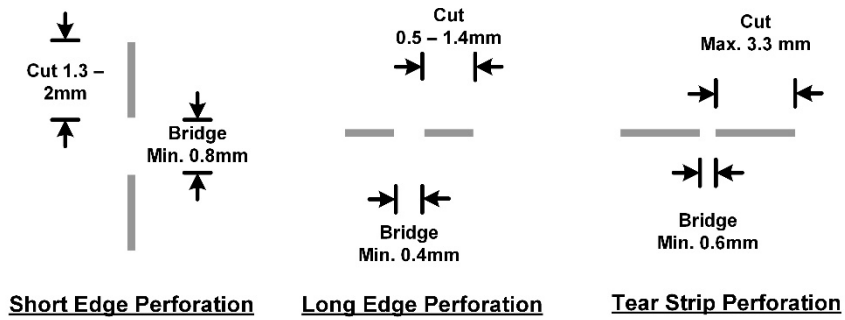

Figure 28 - Roulette Perforation Dimensions (Not to Scale)

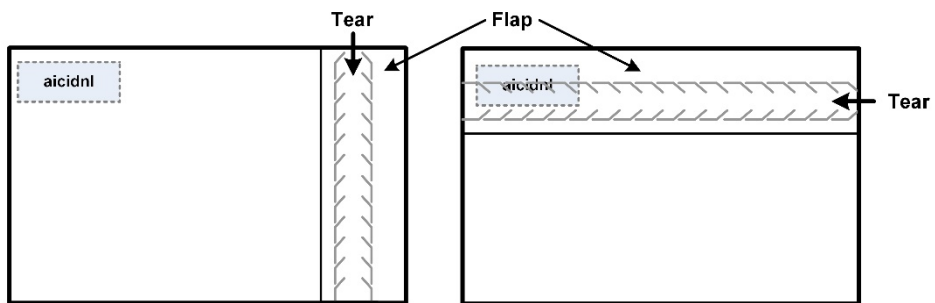

Figure 22 - Zip Tie Letter Orientation (back view) - Landscape Mail (Not to Scale)

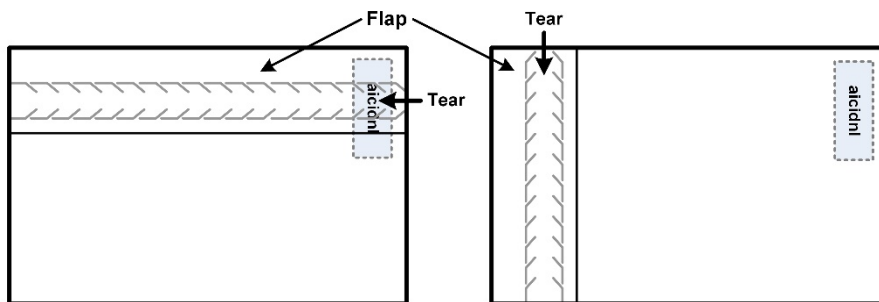

Figure 3023 - Zip Tie Letter Orientation (back view) - Portrait Mail (Not to Scale)

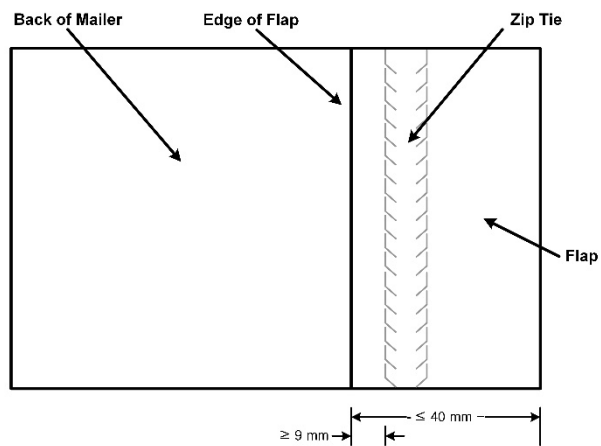

Figure 31 - Zip tie Letter & Envelope Flap (Not to Scale)



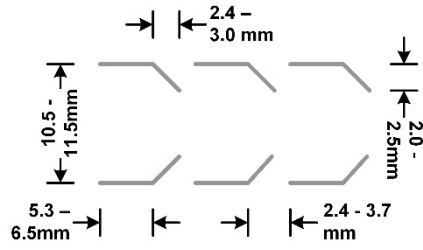

Figure 24 - Zip tie Dimensions (Not to Scale)

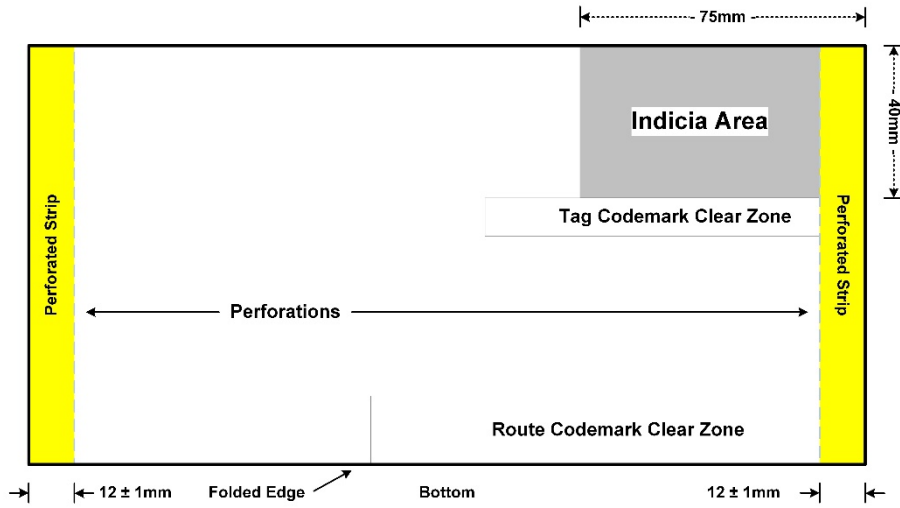

Figure 33 - Pressure Seal Letter Envelope - Front of Letter Perforations (Not to Scale)

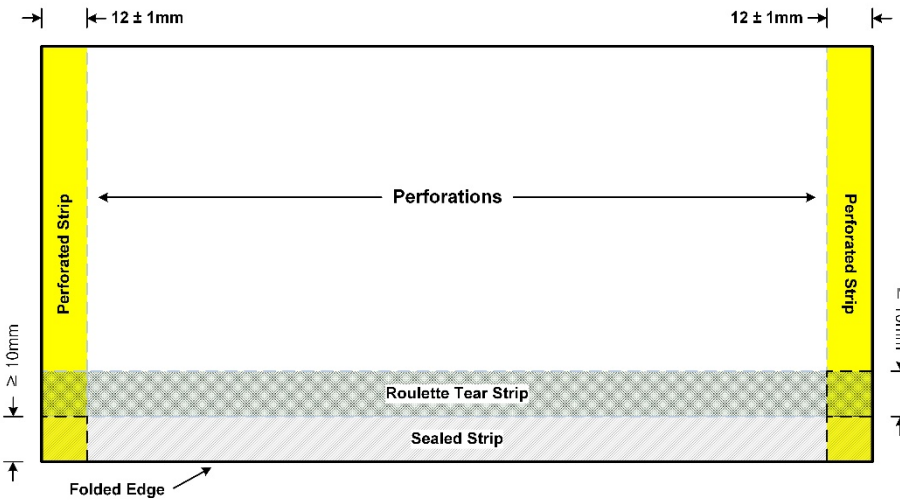

Figure 25 - Pressure Seal Letter Envelope - Back of Letter (Not to Scale)